

HOLE TABLE		
HOLE	X	Y
A,1	.375	-2.125
A,2	6.745	-2.000
A,3	.375	-.500
A,4	6.745	-.375
B,1	.935	-2.125
B,2	6.185	-2.125
B,3	.375	-1.250
B,4	6.745	-1.250
B,5	.935	-.375
B,6	6.185	-.375
C,1	2.250	-1.750
C,2	4.870	-1.750
C,3	3.560	-.750

**CONTENTS:**  
**2637\_BU01**  
**BACKUP PLATE**  
**..**

**XYZ SIZE -- (X) 2.50 x (Y) 7.13 x (Z) .50**  
**MATL -- A-6**  
**MASS -- 2.06 LBS | DENSITY = 0.3**  
**HT TR -- 54-56Rc**  
**ORDER No. --**  
**VENDOR --**

DETAILED **8/27/2002** | LAST SAVE **8/27/2002**

TOLERANCE UNLESS OTHERWISE SPECIFIED  
 .0 DECIMAL ± .030  
 .00 DECIMAL ± .010  
 .000 DECIMAL ± .001  
 ANGULAR ± 1/2°  
 SCREWS ± .010 | DOWELS ± .0005

FILE **2637\_bu01.dft**  
 SCALE **1 / 1 UNLESS NOTED**

SUMMIT TOOL DESIGN WARRANTS THE DRAWING TO BE DIMENSIONALLY CORRECT. CUSTOMER SHALL DETERMINE IF THE DESIGN IS APPROPRIATE FOR THE INTENDED USE.

JOB No. **2637** | DESIGNER **SRC**  
 DETAILER **SRC** | CHECKER **..**

PROJECT **FUEL DOOR HINGE - PROGRESSIVE DIE**  
**CUSTOMER P/N 93874-7S200**



SUMMIT TOOL DESIGN SHALL BE LIABLE SOLELY FOR DIMENSIONAL ERRORS AND SHALL NOT BE LIABLE FOR INCIDENTAL OR CONSEQUENTIAL DAMAGE.

TOOL NO. **..**  
 SHEET **1 OF 1**

HOLE TABLE		
HOLE	X	Y
A,1	.500	-3.188
A,2	2.750	-3.188
A,3	.500	-.313
A,4	2.750	-.313
B,1	1.000	-3.188
B,2	2.000	-.313
C,1	2.000	-3.188
C,2	1.000	-.313
D,1	.938	-1.250

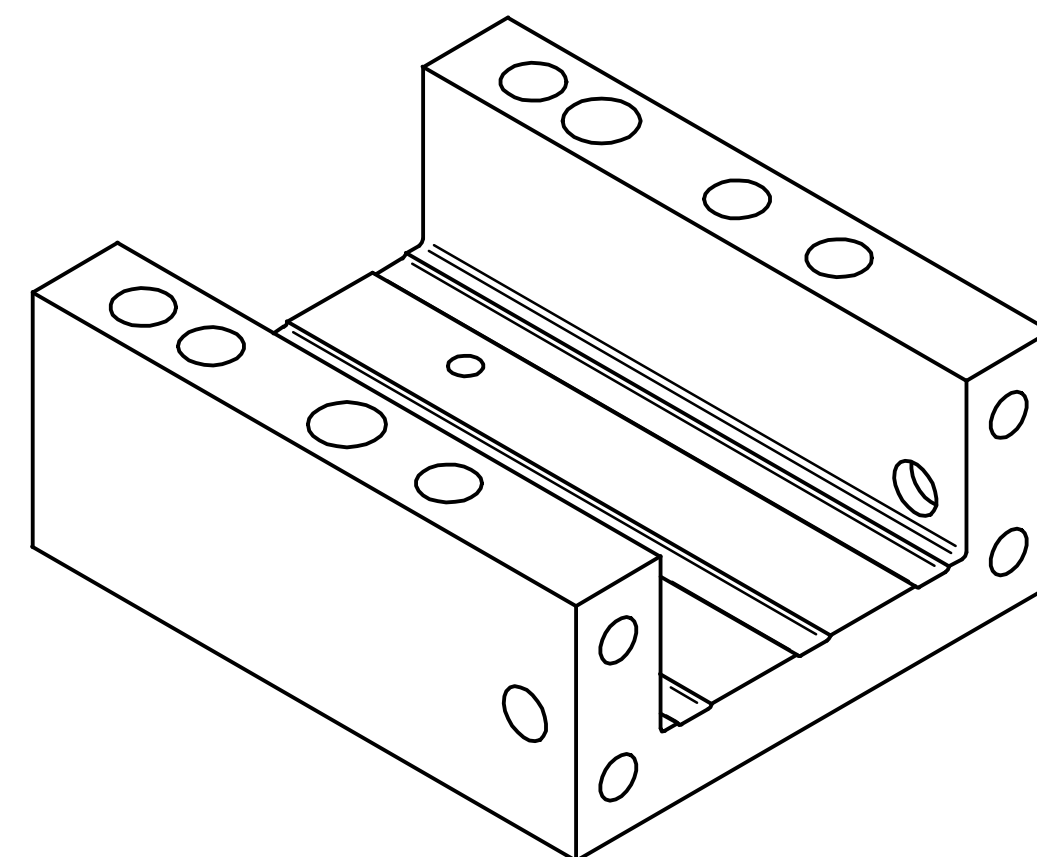
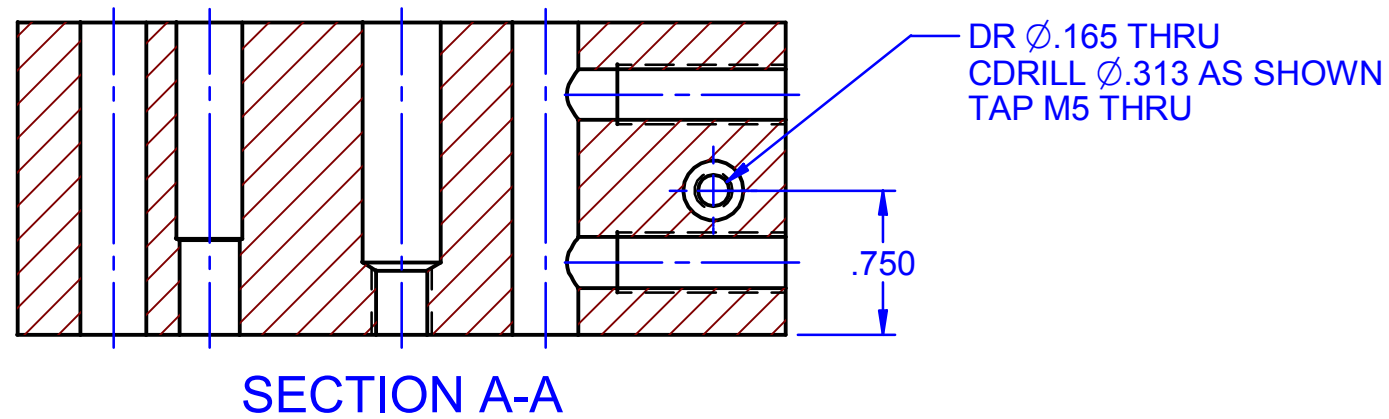
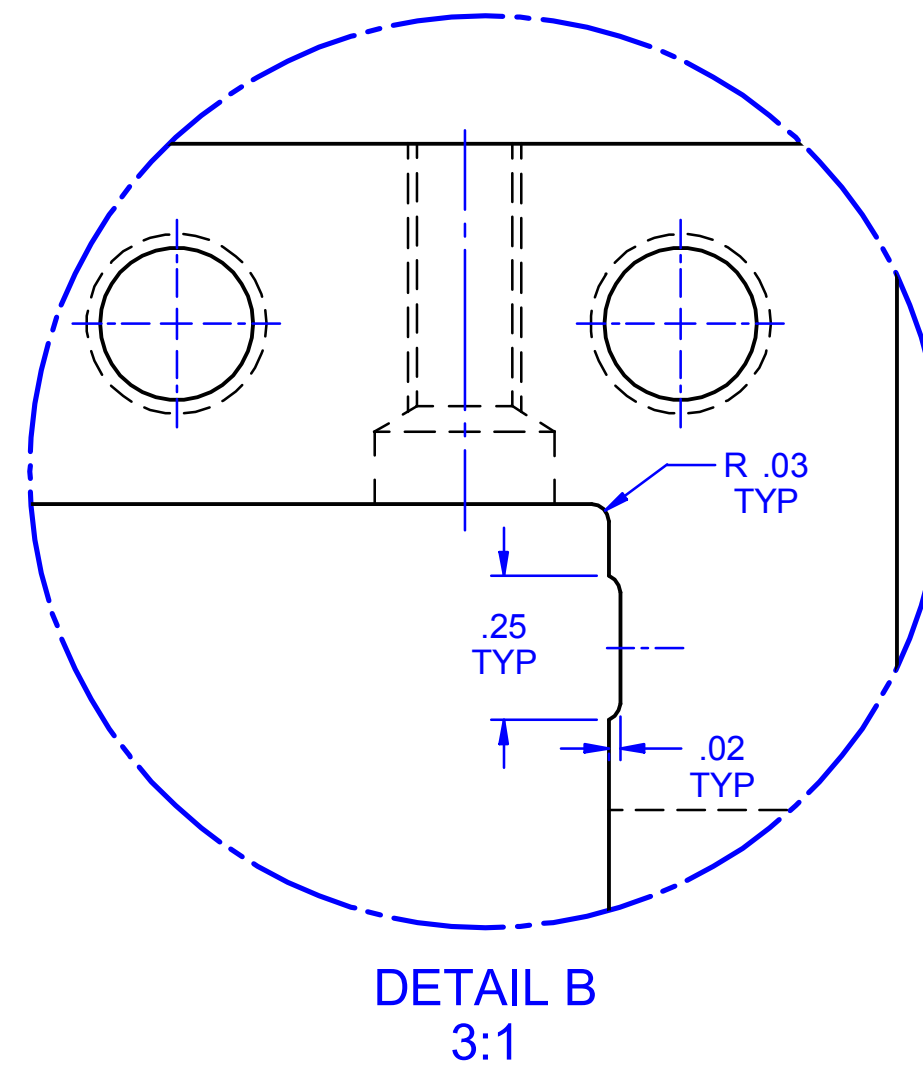
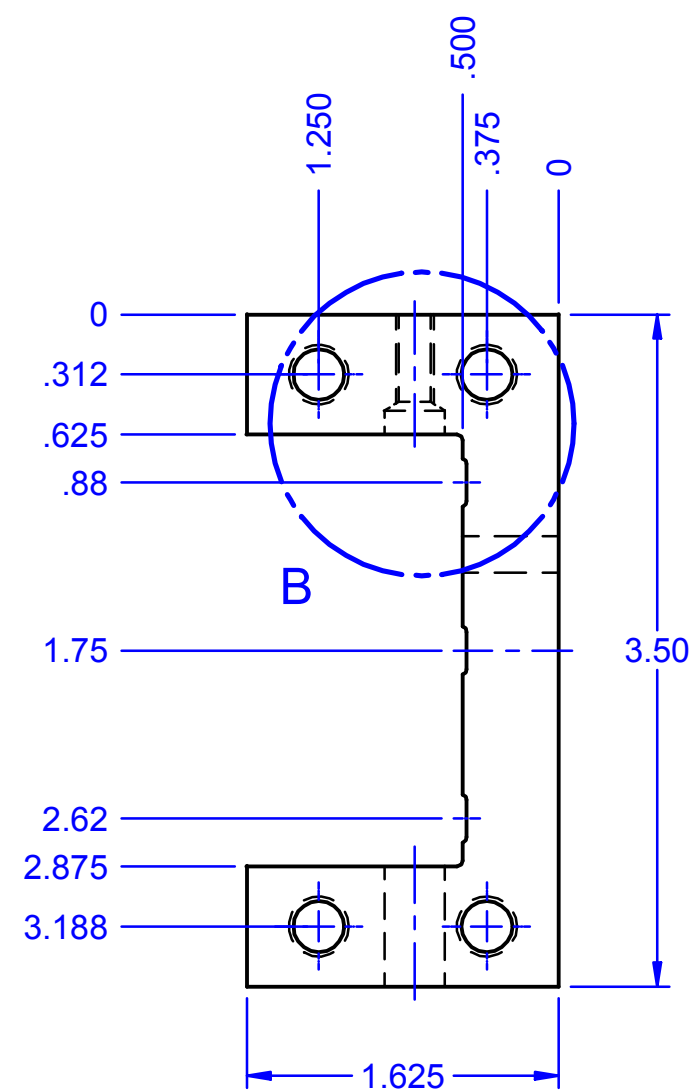
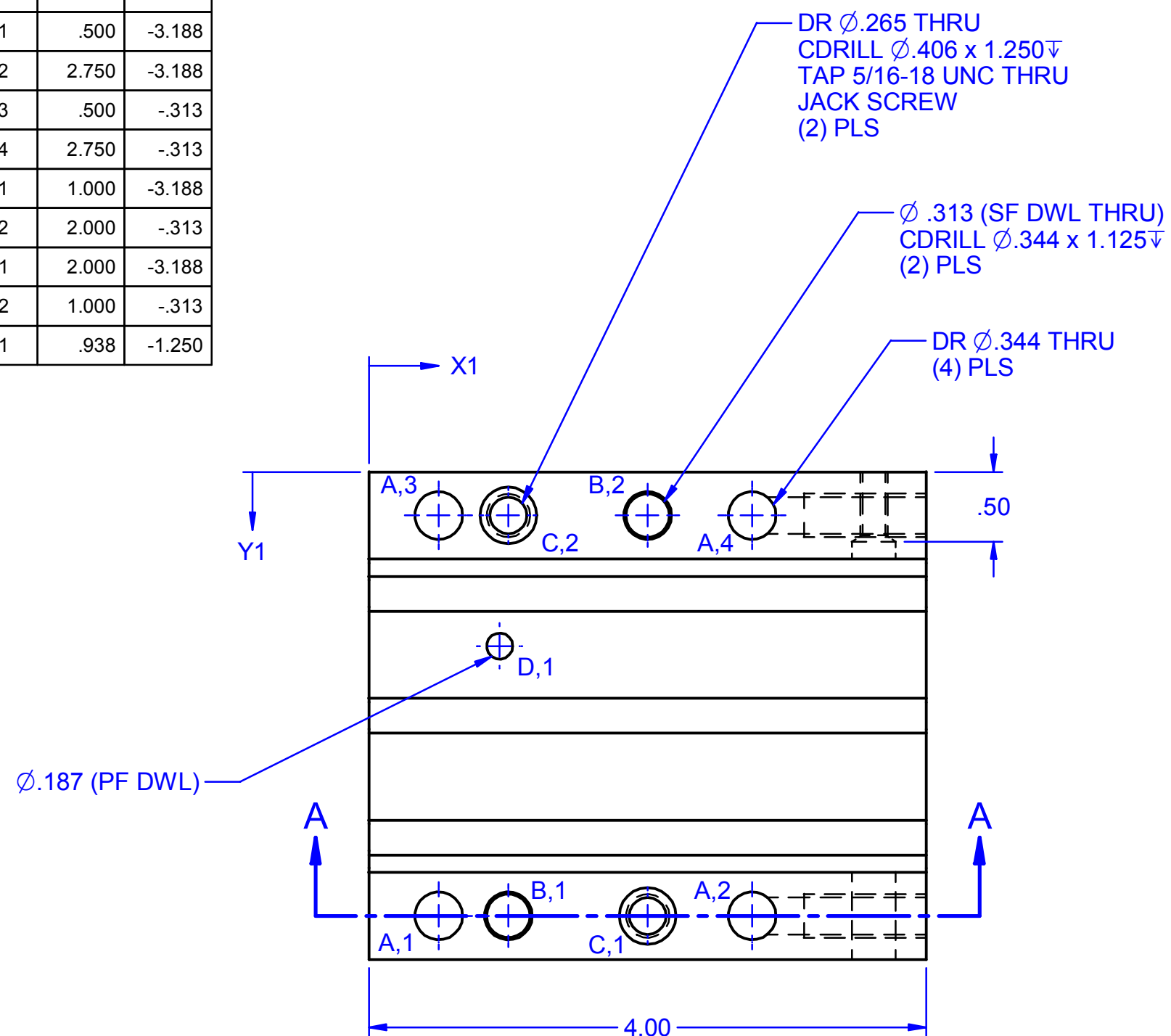

**CONTENTS:**  
**2637\_CC01**  
**SLIDE YOKE**

XYZ SIZE -- (X) 3.50 x (Y) 4.00 x (Z) 1.63  
 MATL -- A-2  
 MASS -- 3.11 LBS | DENSITY = 0.3  
 HT TR -- 59-61Rc  
 ORDER No. --  
 VENDOR --

DETAILED 9/4/2002 LAST SAVE 9/4/2002

TOLERANCE UNLESS OTHERWISE SPECIFIED  
 .0 DECIMAL ± .030  
 .00 DECIMAL ± .010  
 .000 DECIMAL ± .001  
 ANGULAR ± 1/2°  
 SCREWS ± .010 | DOWELS ± .0005

FILE 2637\_cc01.dft  
 SCALE 1/1 UNLESS NOTED  
 JOB No. 2637  
 DESIGNER SRC  
 DETAILER SRC  
 CHECKER ..

SUMMIT TOOL DESIGN WARRANTS THE DRAWING TO BE DIMENSIONALLY CORRECT. CUSTOMER SHALL DETERMINE IF THE DESIGN IS APPROPRIATE FOR THE INTENDED USE.

SUMMIT TOOL DESIGN SHALL BE LIABLE SOLELY FOR DIMENSIONAL ERRORS AND SHALL NOT BE LIABLE FOR INCIDENTAL OR CONSEQUENTIAL DAMAGE.

PROJECT **FUEL DOOR HINGE - PROGRESSIVE DIE**  
**CUSTOMER P/N 93874-7S200**



TOOL NO. ..  
 SHEET 1 OF 1

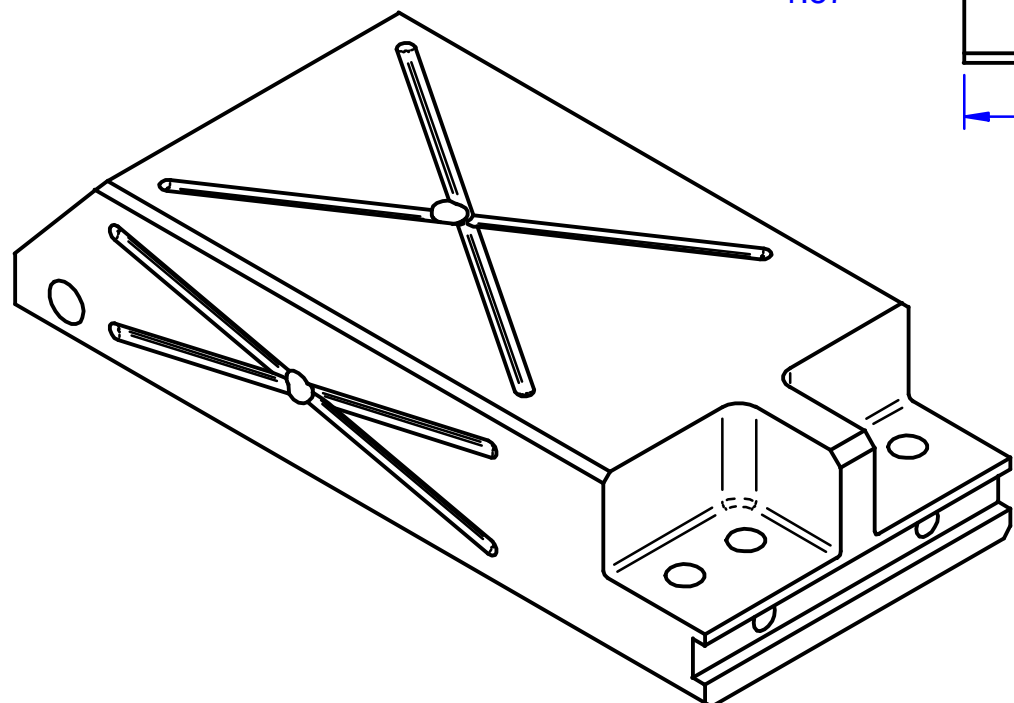
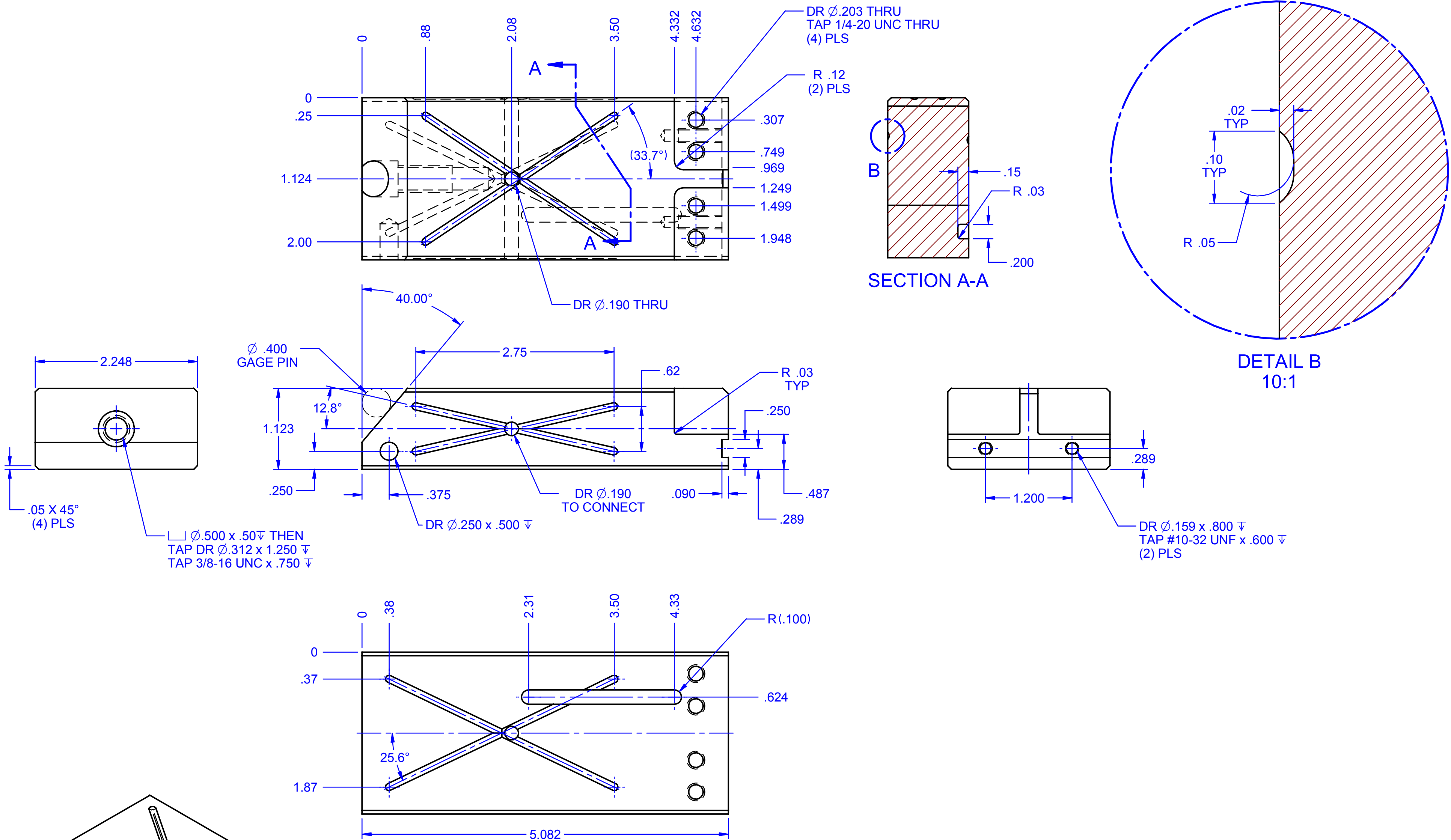

<b>CONTENTS:</b> <b>2637_CC02</b> <b>SLIDE</b> ..		XYZ SIZE -- (X) 2.25 x (Y) 3.75 x (Z) 1.13 MATL -- A-2 MASS -- 3.06 LBS   DENSITY = 0.3 HT TR -- 59-61Rc ORDER No. -- VENDOR --	
DETAILED 9/4/2002	LAST SAVE 9/4/2002	TOLERANCE UNLESS OTHERWISE SPECIFIED .0 DECIMAL ± .030 .00 DECIMAL ± .010 .000 DECIMAL ± .001 ANGULAR ± 1/2° SCREWS ± .010   DOWELS ± .0005	FILE 2637_cc02.dft SCALE 1/1 UNLESS NOTED JOB No. 2637 DESIGNER SRC
SUMMIT TOOL DESIGN WARRANTS THE DRAWING TO BE DIMENSIONALLY CORRECT. CUSTOMER SHALL DETERMINE IF THE DESIGN IS APPROPRIATE FOR THE INTENDED USE. SUMMIT TOOL DESIGN SHALL BE LIABLE SOLELY FOR DIMENSIONAL ERRORS AND SHALL NOT BE LIABLE FOR INCIDENTAL OR CONSEQUENTIAL DAMAGE.		PROJECT <b>FUEL DOOR HINGE - PROGRESSIVE DIE</b> <b>CUSTOMER P/N 93874-7S200</b>	DETAILER SRC CHECKER ..
			
		TOOL NO. .. SHEET 1 OF 1	

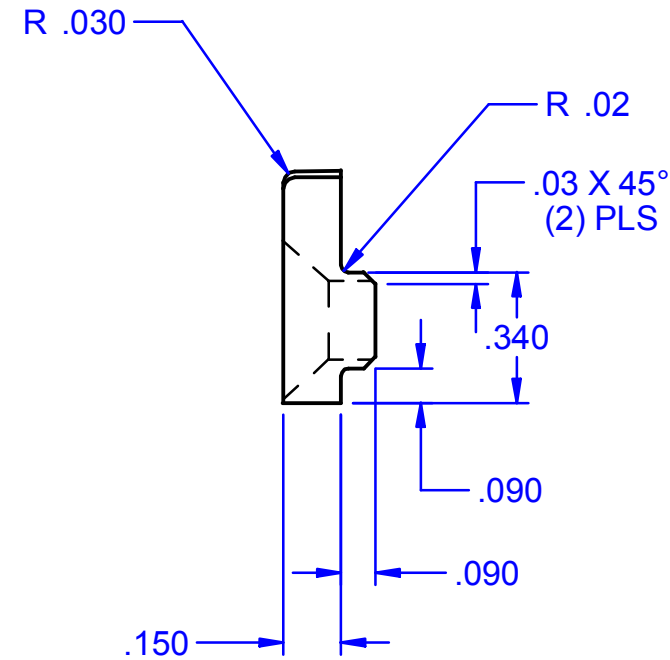
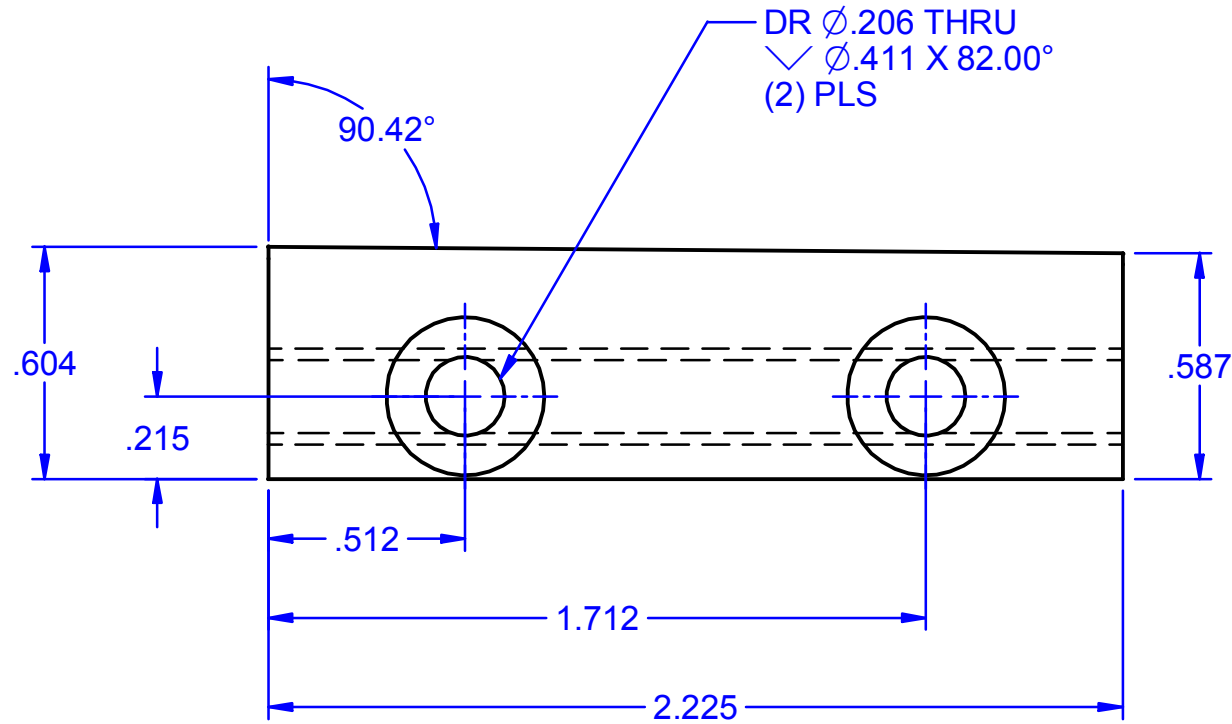
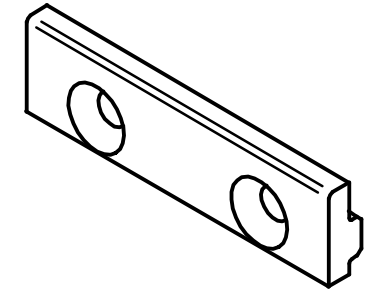

**CONTENTS:**

**2637\_CC03**  
**SUPPORT INSERT**

..

XYZ SIZE -- (X) 2.23 x (Y) .24 x (Z) .61  
 MATL -- D-2  
 MASS -- 0.06 LBS | DENSITY = 0.3  
 HT TR -- 59-61Rc  
 ORDER No. --  
 VENDOR --

DETAILED  
**9/4/2002**

LAST SAVE  
**9/4/2002**

TOLERANCE UNLESS  
 OTHERWISE SPECIFIED

.0 DECIMAL  $\pm$  .030  
 .00 DECIMAL  $\pm$  .010  
 .000 DECIMAL  $\pm$  .001  
 ANGULAR  $\pm$  1/2°  
 SCREWS  $\pm$  .010 | DOWELS  $\pm$  .0005

FILE **2637\_cc03.dft**

SCALE **2 / 1 UNLESS NOTED**

JOB No. **2637**

DETAILER **SRC**

DESIGNER **SRC**

CHECKER **..**

SUMMIT TOOL DESIGN WARRANTS THE DRAWING TO BE DIMENSIONALLY CORRECT. CUSTOMER SHALL DETERMINE IF THE DESIGN IS APPROPRIATE FOR THE INTENDED USE.

SUMMIT TOOL DESIGN SHALL BE LIABLE SOLELY FOR DIMENSIONAL ERRORS AND SHALL NOT BE LIABLE FOR INCIDENTAL OR CONSEQUENTIAL DAMAGE.

PROJECT **FUEL DOOR HINGE - PROGRESSIVE DIE**  
**CUSTOMER P/N 93874-7S200**



TOOL NO. **..**

SHEET **1 OF 1**

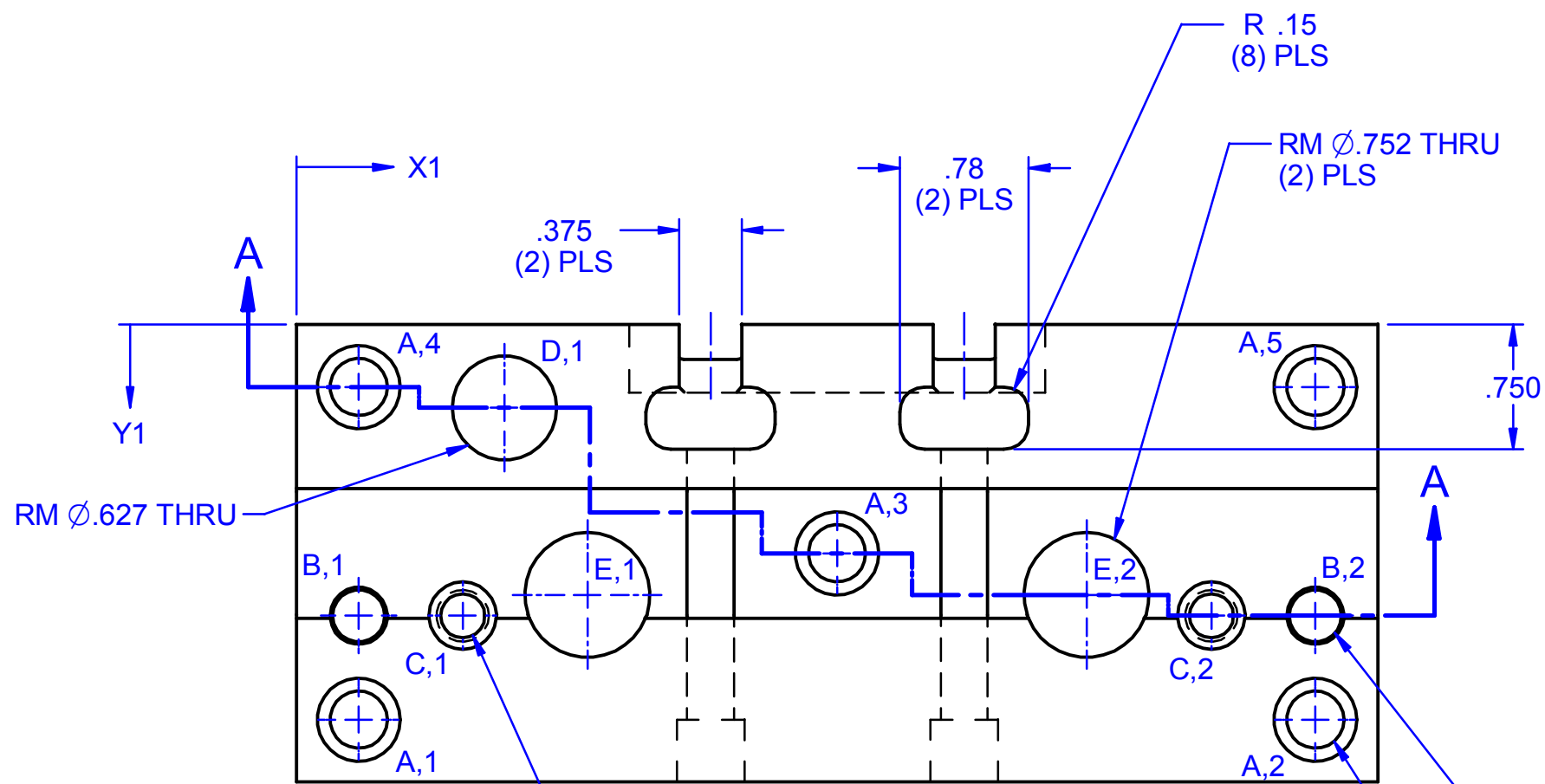

HOLE TABLE		
HOLE	X	Y
A,1	.375	-2.375
A,2	6.125	-2.375
A,3	3.250	-1.375
A,4	.375	-.375
A,5	6.125	-.375
B,1	.375	-1.750
B,2	6.125	-1.750
C,1	1.000	-1.750
C,2	5.500	-1.750
D,1	1.250	-.500
E,1	1.750	-1.625
E,2	4.750	-1.625

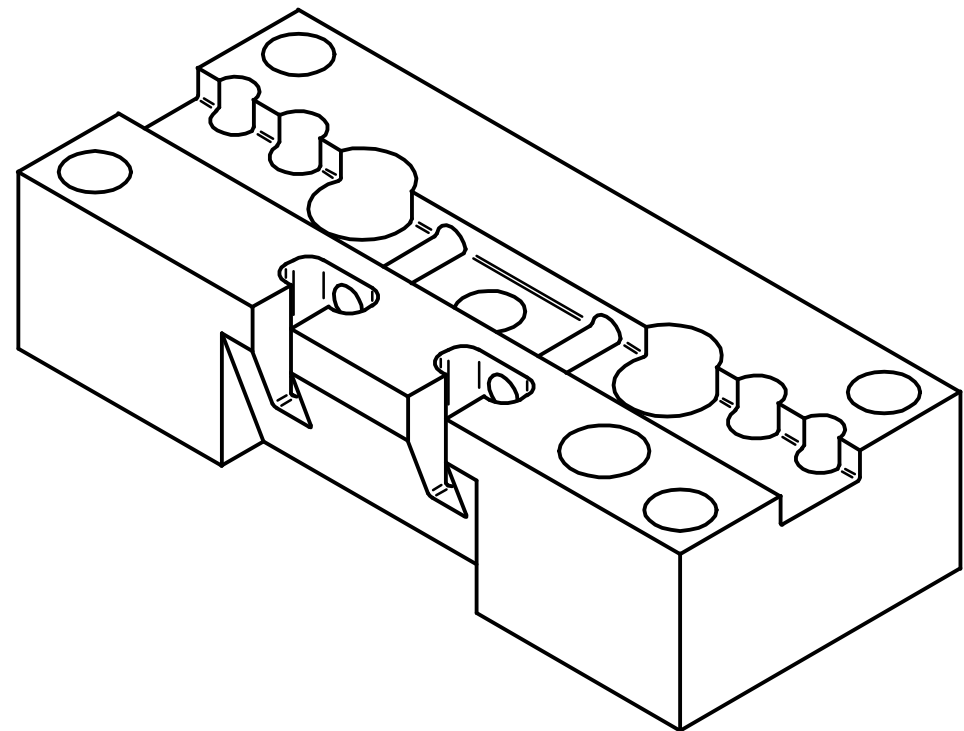
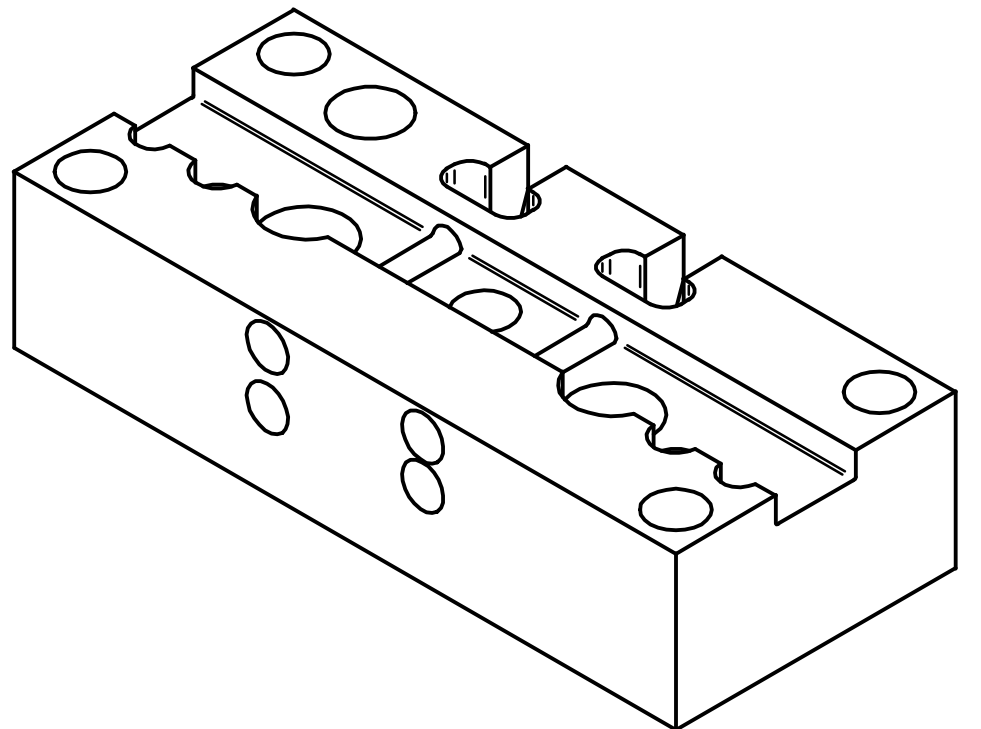

HOLE TABLE		
HOLE	X	Y
AA,1	2.490	1.250
AA,2	2.490	.737
AA,3	4.015	.830
AA,4	4.015	1.250

DR Ø.265 THRU  
CDRILL Ø.406 x 1.000  
TAP 5/16-18 UNC THRU  
JACK SCREW  
(2) PLS

Ø .313 (SF DWL THRU)  
CDRILL Ø.344 x .750  
(2) PLS

DR Ø.344 THRU  
□ Ø.500 x .750  
(5) PLS

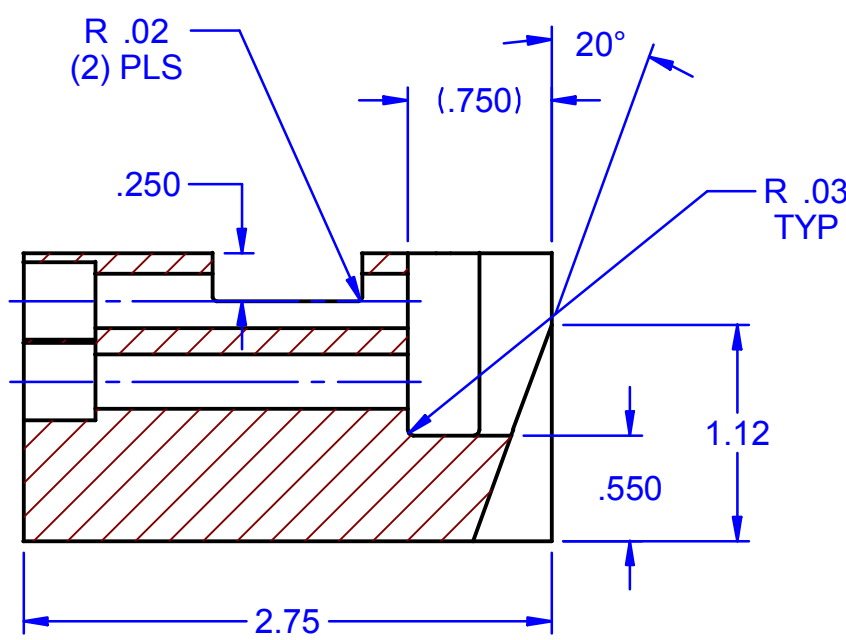
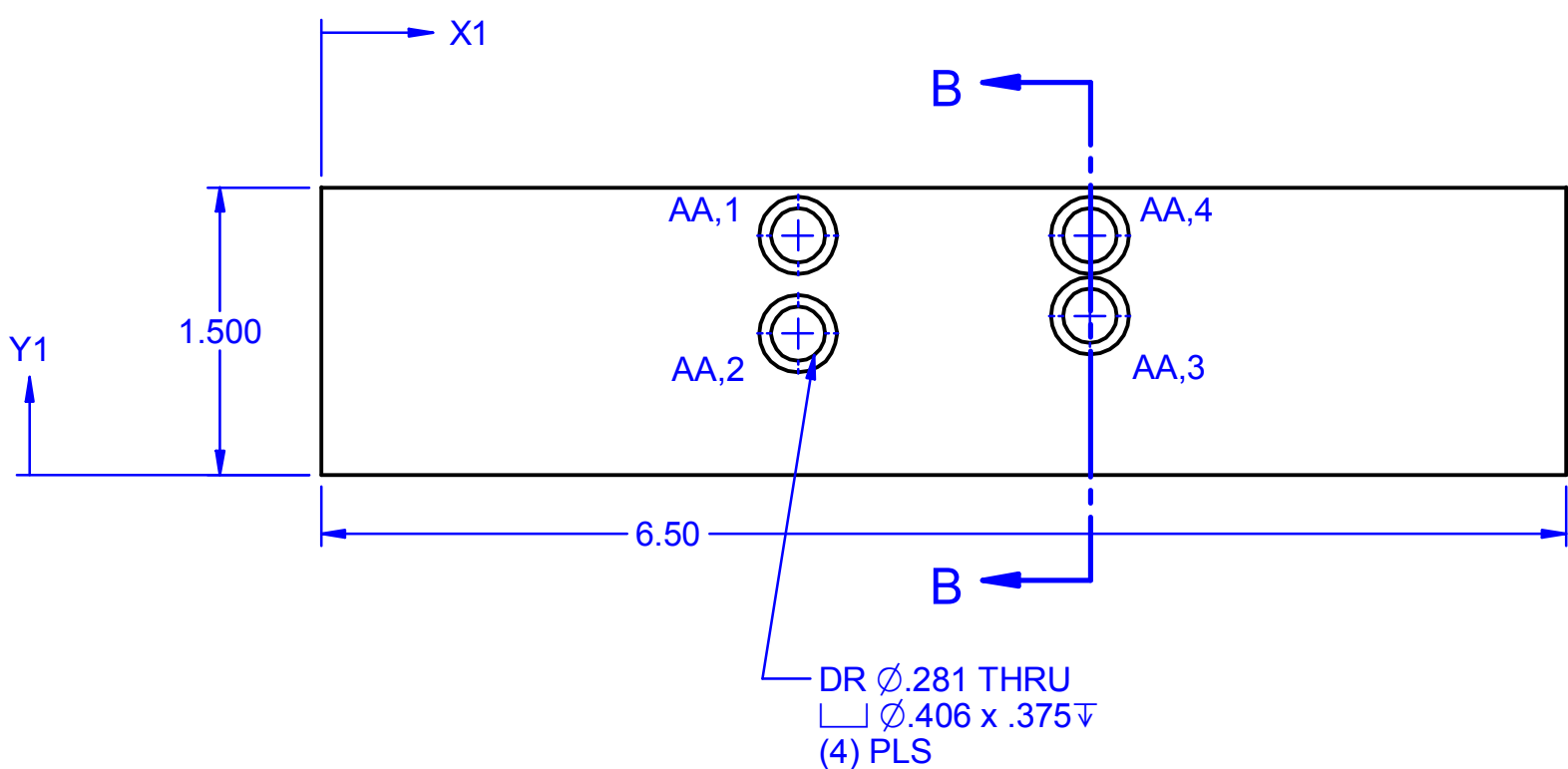

SECTION B-B

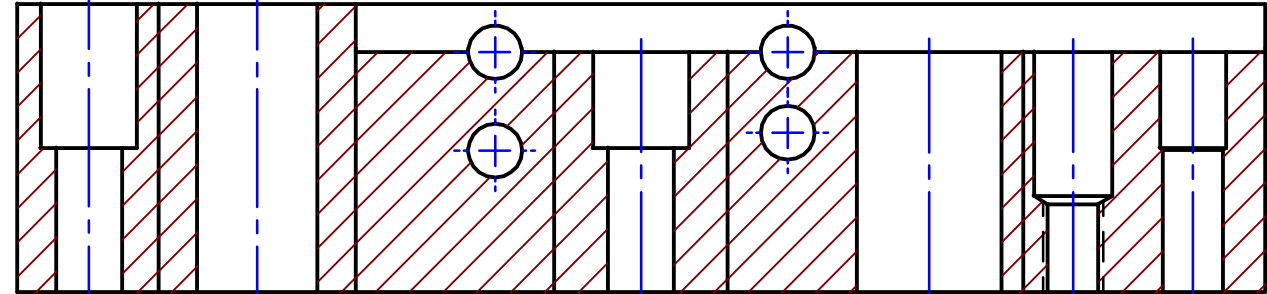

SECTION A-A

**CONTENTS:**  
**2637\_DB06**  
**DIE BLOCK**

XYZ SIZE -- (X) 6.50 x (Y) 2.75 x (Z) 1.50  
MATL -- A-2  
MASS -- 5.81 LBS | DENSITY = 0.3  
HT TR -- 58-60Rc  
ORDER No. --  
VENDOR --

DETAILED 9/5/2002 LAST SAVE 9/5/2002

TOLERANCE UNLESS OTHERWISE SPECIFIED  
.00 DECIMAL ± .030  
.00 DECIMAL ± .010  
.000 DECIMAL ± .001  
ANGULAR ± 1/2°  
SCREWS ± .010 | DOWELS ± .0005

FILE 2637\_db06.dft  
SCALE 1/1 UNLESS NOTED  
JOB No. 2637  
DESIGNER SRC  
DETAILER SRC  
CHECKER ..

SUMMIT TOOL DESIGN WARRANTS THE DRAWING TO BE DIMENSIONALLY CORRECT. CUSTOMER SHALL DETERMINE IF THE DESIGN IS APPROPRIATE FOR THE INTENDED USE.  
SUMMIT TOOL DESIGN SHALL BE LIABLE SOLELY FOR DIMENSIONAL ERRORS AND SHALL NOT BE LIABLE FOR INCIDENTAL OR CONSEQUENTIAL DAMAGE.

PROJECT **FUEL DOOR HINGE - PROGRESSIVE DIE**  
**CUSTOMER P/N 93874-7S200**



TOOL NO. ..  
SHEET 1 OF 1

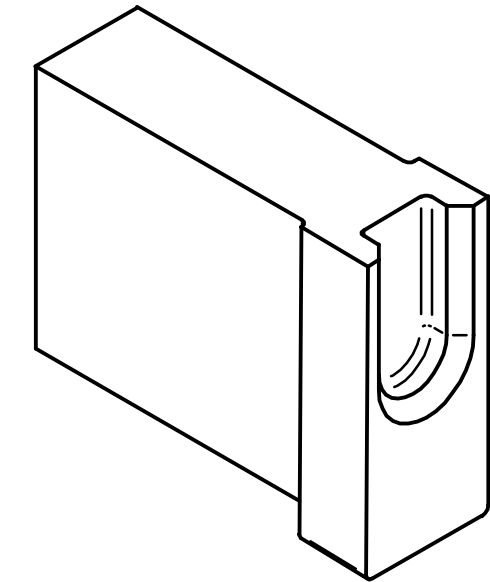
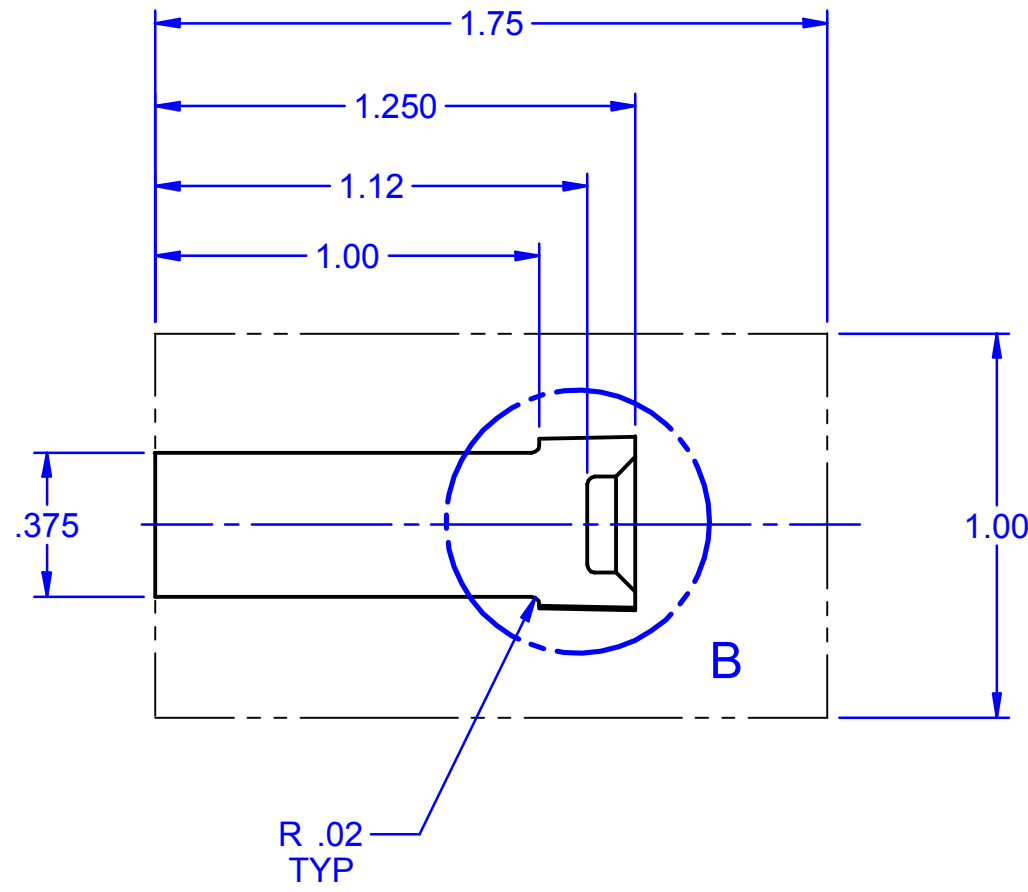
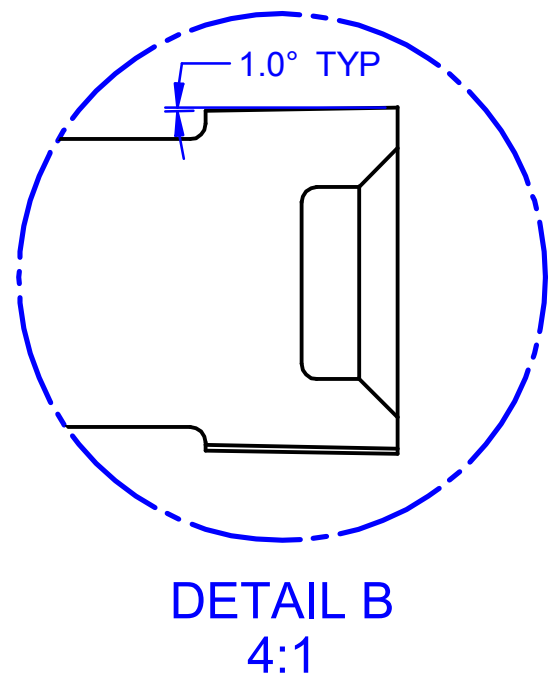

**WIRE CUT TO FINAL  
BLANK DEVELOPMENT**

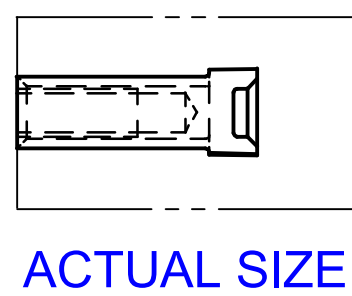
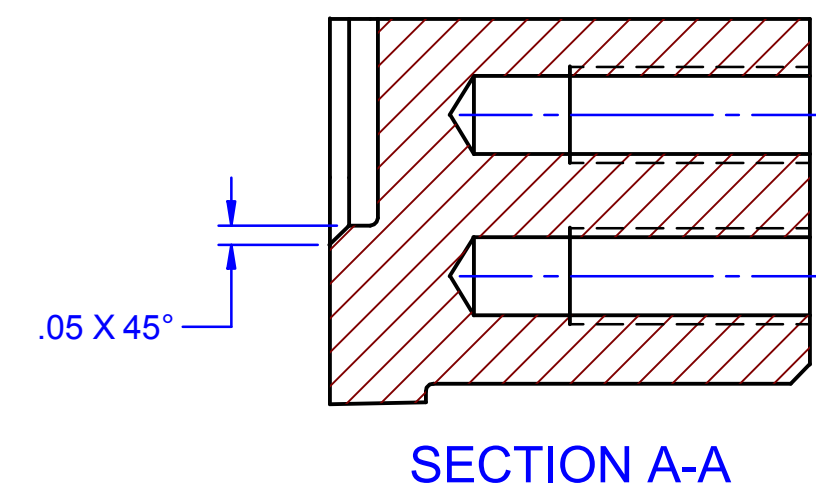
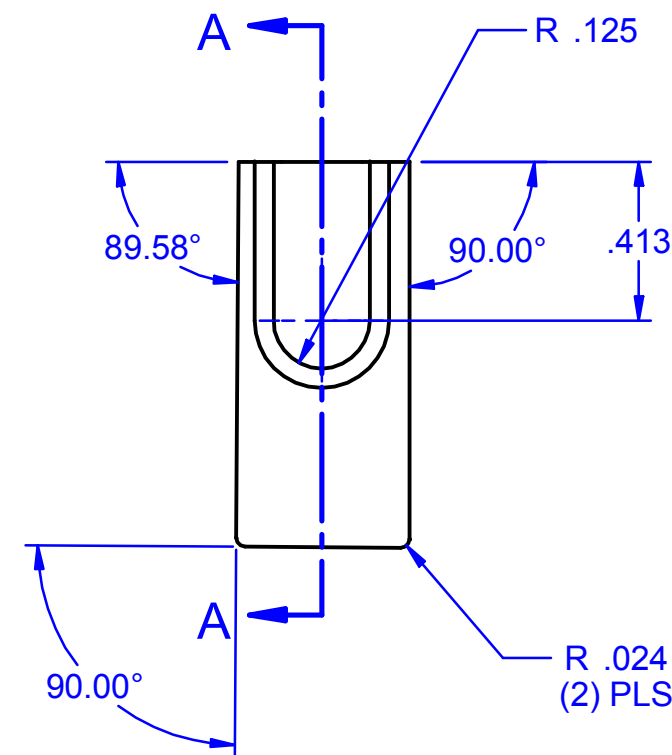
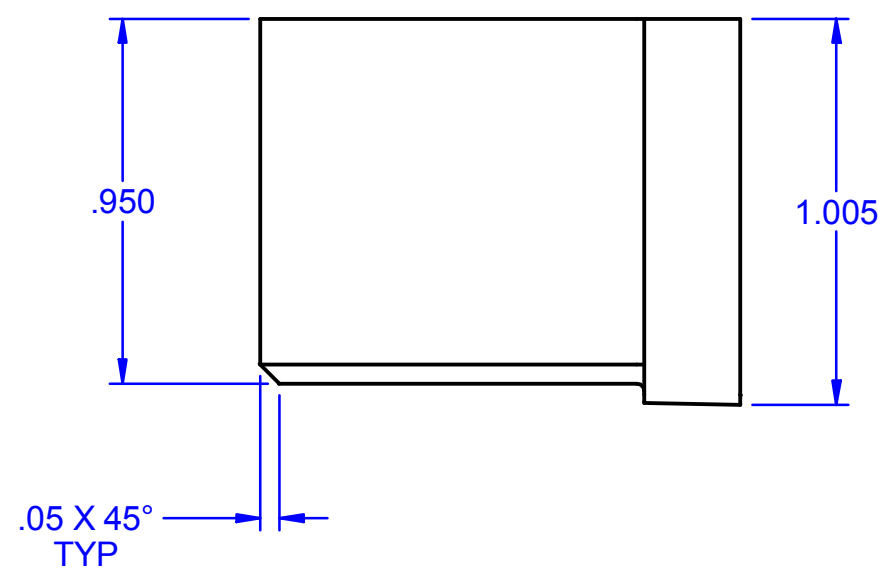
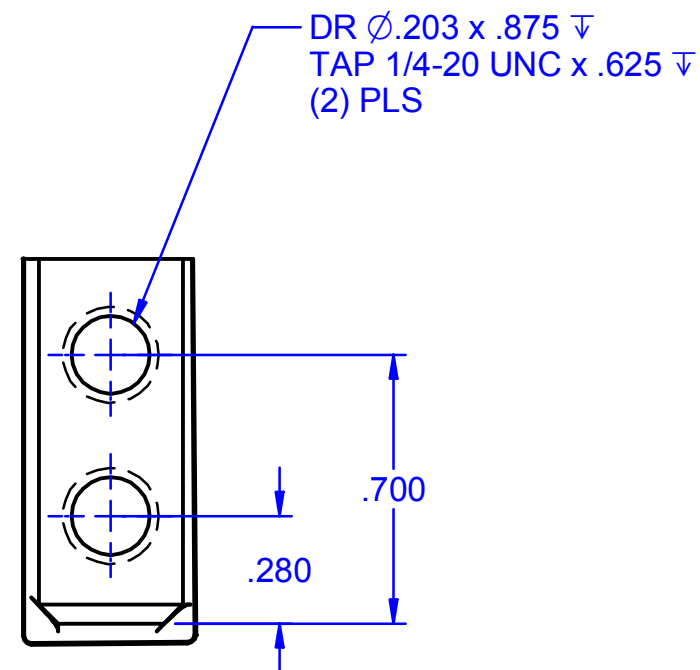

**CONTENTS:**

**2637\_DB08**  
**DIE BLOCK - TRIM INSERT**

XYZ SIZE -- (X) 1.00 x (Y) 1.75 x (Z) 1.12  
MATL -- M-2  
MASS -- 0.11 LBS | DENSITY = 0.3  
HT TR -- 60-62Rc  
ORDER No. --  
VENDOR --

DETAILED 9/5/2002 LAST SAVE 9/5/2002

TOLERANCE UNLESS OTHERWISE SPECIFIED

FILE 2637\_db08.dft

SCALE 2 / 1 UNLESS NOTED

SUMMIT TOOL DESIGN WARRANTS THE DRAWING TO BE DIMENSIONALLY CORRECT. CUSTOMER SHALL DETERMINE IF THE DESIGN IS APPROPRIATE FOR THE INTENDED USE.

.0 DECIMAL ± .030  
.00 DECIMAL ± .010  
.000 DECIMAL ± .001  
ANGULAR ± 1/2°  
SCREWS ± .010 | DOWELS ± .0005

JOB No. 2637

DETAILER SRC

DESIGNER SRC

CHECKER ..

SUMMIT TOOL DESIGN SHALL BE LIABLE SOLELY FOR DIMENSIONAL ERRORS AND SHALL NOT BE LIABLE FOR INCIDENTAL OR CONSEQUENTIAL DAMAGE.

PROJECT **FUEL DOOR HINGE - PROGRESSIVE DIE**  
**CUSTOMER P/N 93874-7S200**



TOOL NO. ..  
SHEET 1 OF 1

HOLE TABLE		
HOLE	X	Y
A,1	.500	-3.000
A,2	3.125	-3.000
A,3	5.750	-3.000
A,4	.500	-.500
A,5	3.125	-.500
A,6	5.750	-.500
B,1	1.250	-.500
C,1	1.750	-.500

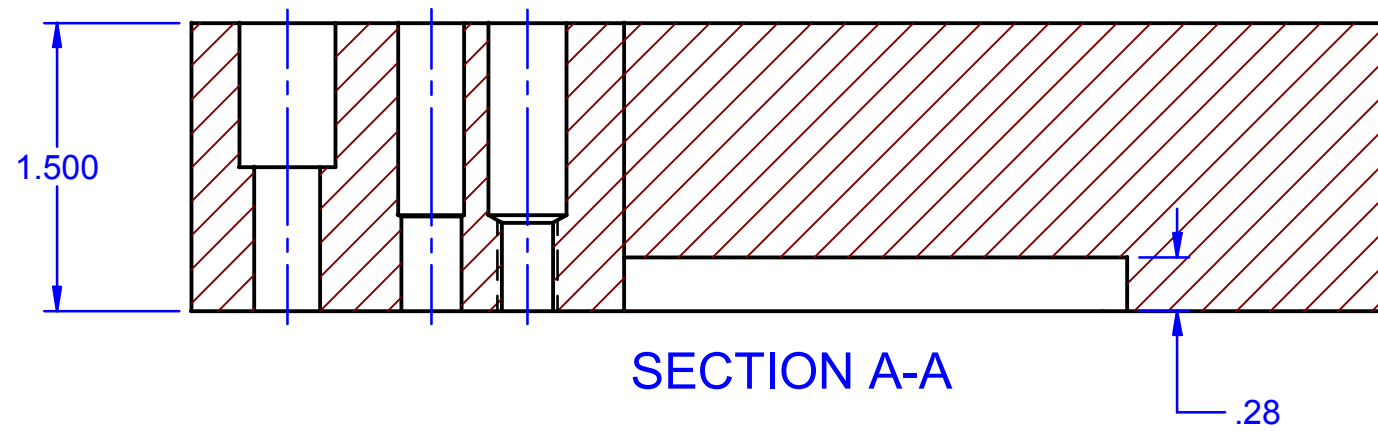
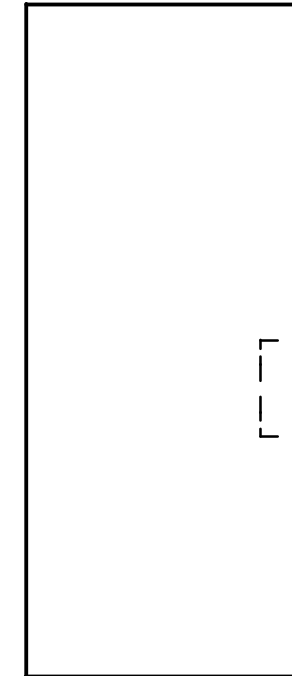
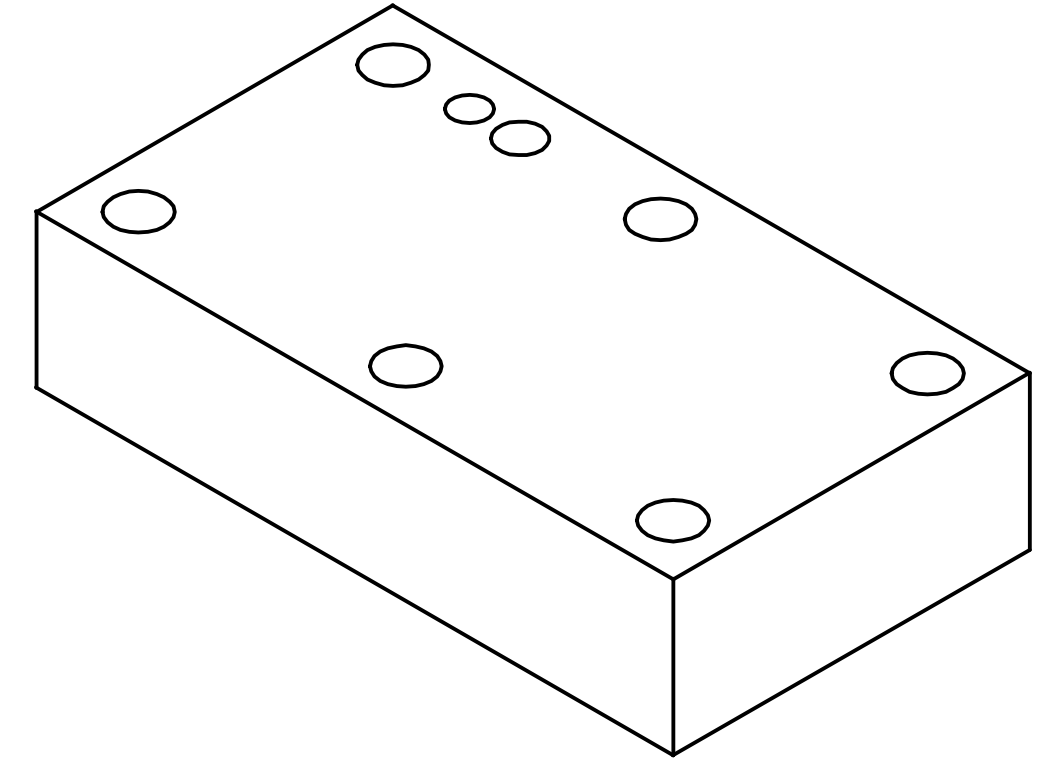
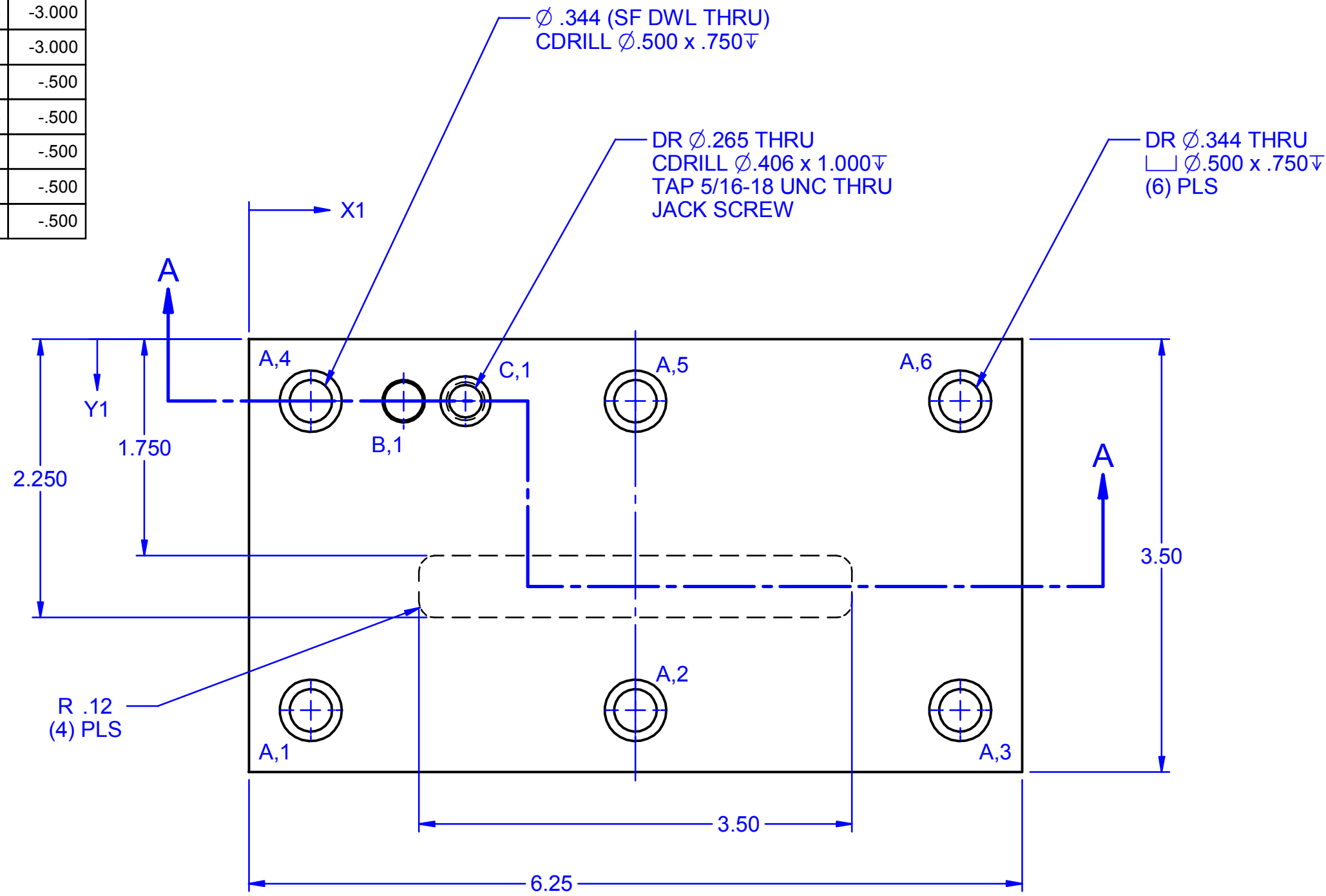

**CONTENTS:**  
**2637\_DB10**  
**DIE BLOCK**

XYZ SIZE -- (X) 6.25 x (Y) 3.50 x (Z) 1.50  
 MATL -- A-2  
 MASS -- 8.71 LBS | DENSITY = 0.3  
 HT TR -- 59-61Rc  
 ORDER No. --  
 VENDOR --

DETAILED **9/5/2002** LAST SAVE **9/5/2002**

TOLERANCE UNLESS OTHERWISE SPECIFIED  
 .0 DECIMAL ± .030  
 .00 DECIMAL ± .010  
 .000 DECIMAL ± .001  
 ANGULAR ± 1/2'  
 SCREWS ± .010 | DOWELS ± .0005

FILE **2637\_db10.dft**  
 SCALE **1 / 1 UNLESS NOTED**

JOB No. **2637** DETAILER **SRC**  
 DESIGNER **SRC** CHECKER **..**

SUMMIT TOOL DESIGN WARRANTS THE DRAWING TO BE DIMENSIONALLY CORRECT. CUSTOMER SHALL DETERMINE IF THE DESIGN IS APPROPRIATE FOR THE INTENDED USE.

SUMMIT TOOL DESIGN SHALL BE LIABLE SOLELY FOR DIMENSIONAL ERRORS AND SHALL NOT BE LIABLE FOR INCIDENTAL OR CONSEQUENTIAL DAMAGE.

PROJECT **FUEL DOOR HINGE - PROGRESSIVE DIE**  
**CUSTOMER P/N 93874-7S200**



TOOL NO. **..**  
 SHEET **1 OF 1**

# WIRE CUT TO FINAL BLANK DEVELOPMENT

HOLE TABLE		
HOLE	X	Y
A,1	.225	.250
A,2	2.775	.250
B,1	1.500	.250
B,2	.225	.875
B,3	2.775	.875
C,1	.225	.531
C,2	2.775	.531
D,1	.742	.617
E,1	2.258	.633

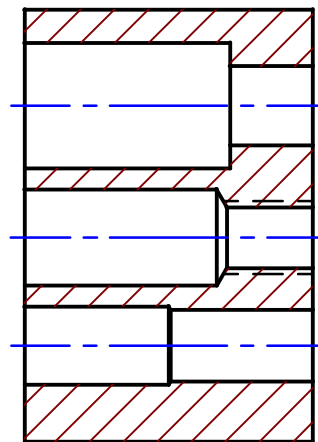
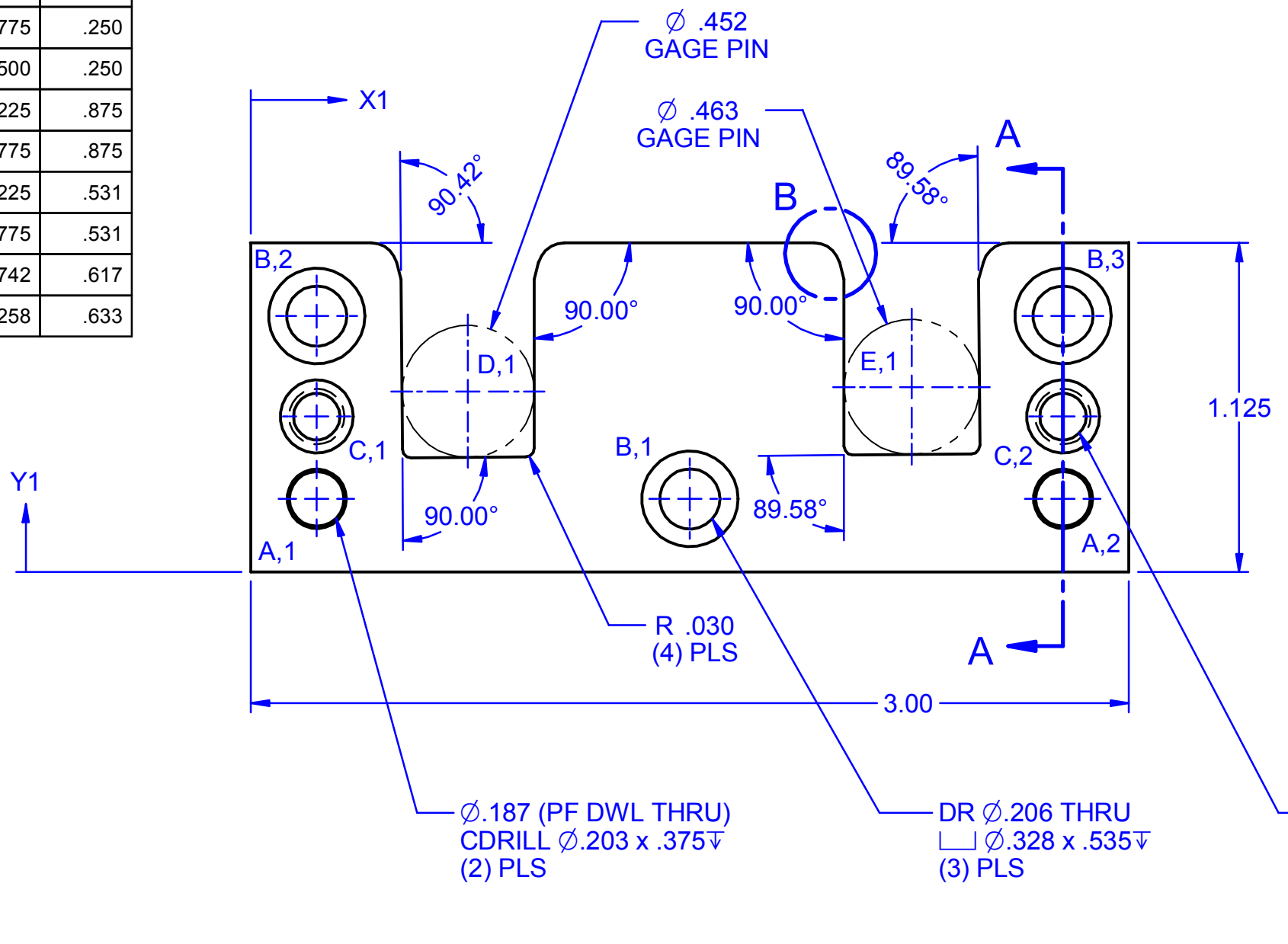
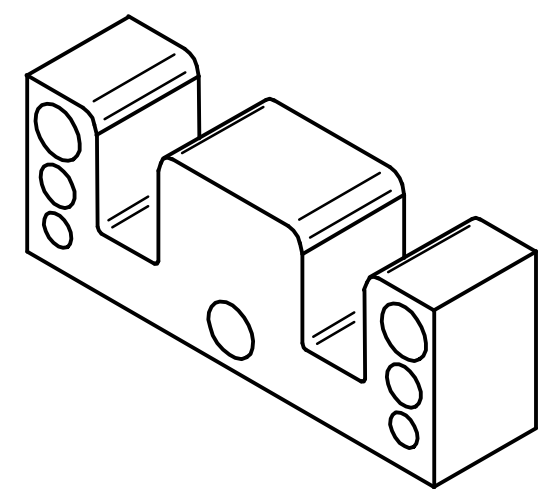
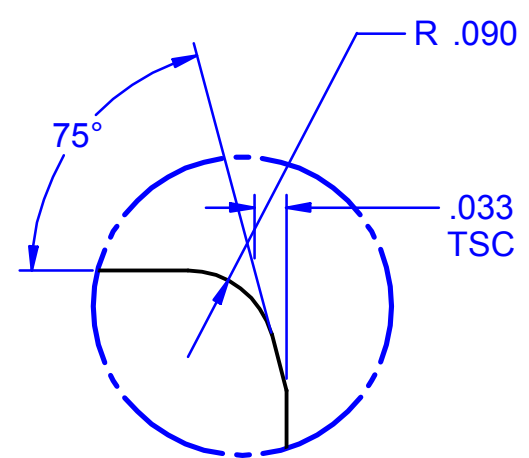

SECTION A-A

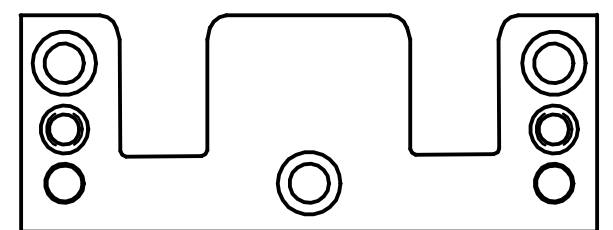

ACTUAL SIZE

<b>CONTENTS:</b> <b>2637_DB11</b> <b>TRIM BLADE</b> ..		XYZ SIZE -- (X) 3.00 x (Y) .75 x (Z) 1.13 MATL -- M-2 MASS -- 0.50 LBS   DENSITY = 0.3 HT TR -- 60-62Rc ORDER No. -- VENDOR --	
DETAILED 9/5/2002	LAST SAVE 9/5/2002	TOLERANCE UNLESS OTHERWISE SPECIFIED .0 DECIMAL ± .030 .00 DECIMAL ± .010 .000 DECIMAL ± .001 ANGULAR ± 1/2° SCREWS ± .010   DOWELS ± .0005	FILE 2637_db11.dft SCALE 2 / 1 UNLESS NOTED JOB No. 2637 DESIGNER SRC PROJECT <b>FUEL DOOR HINGE - PROGRESSIVE DIE</b> <b>CUSTOMER P/N 93874-7S200</b>
SUMMIT TOOL DESIGN WARRANTS THE DRAWING TO BE DIMENSIONALLY CORRECT. CUSTOMER SHALL DETERMINE IF THE DESIGN IS APPROPRIATE FOR THE INTENDED USE. SUMMIT TOOL DESIGN SHALL BE LIABLE SOLELY FOR DIMENSIONAL ERRORS AND SHALL NOT BE LIABLE FOR INCIDENTAL OR CONSEQUENTIAL DAMAGE.		DETAILER SRC CHECKER ..	
		TOOL NO. .. SHEET 1 OF 1	



HOLE TABLE		
HOLE	X	Y
A,1	.250	-1.750
A,2	1.500	-1.750
A,3	.250	-.750
A,4	1.500	-.250
B,1	.250	-1.425
C,1	.831	-1.240
D,1	.250	-1.125
E,1	.831	-.500
F,1	.179	-.444
G,1	.875	-2.069

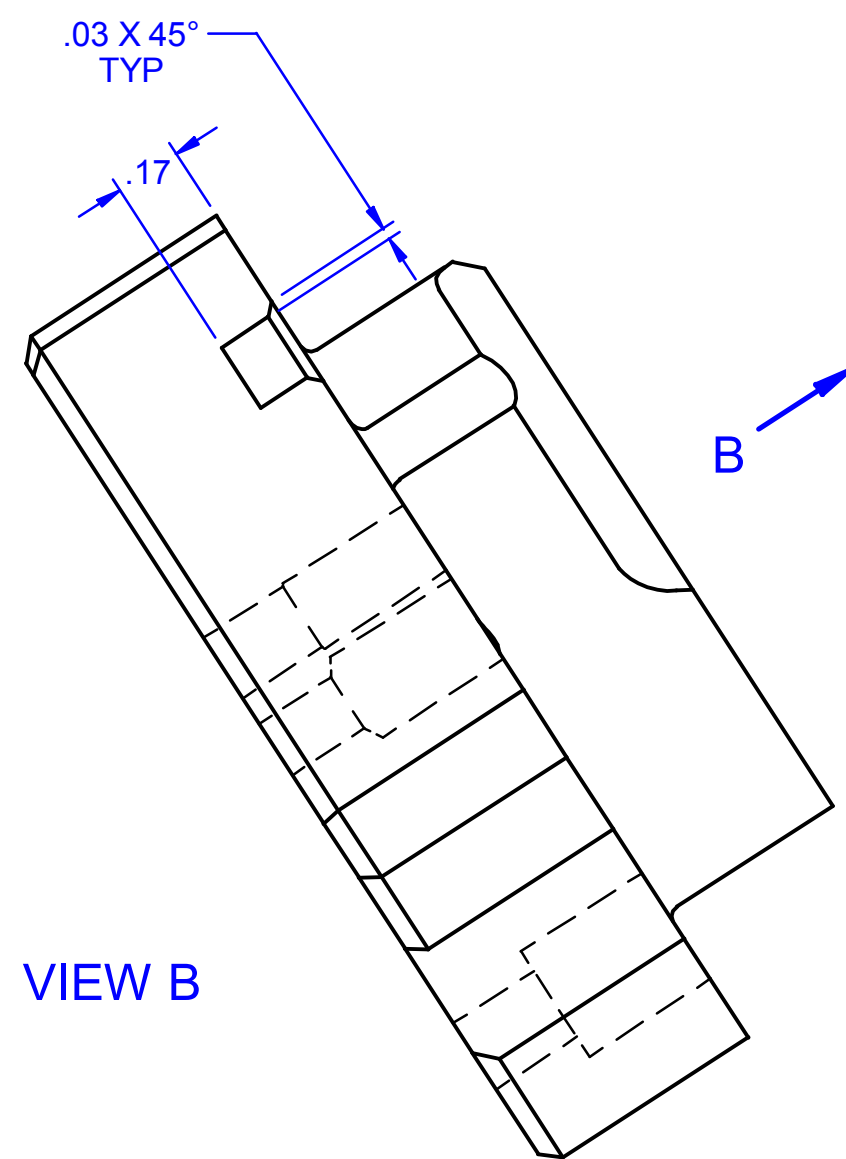
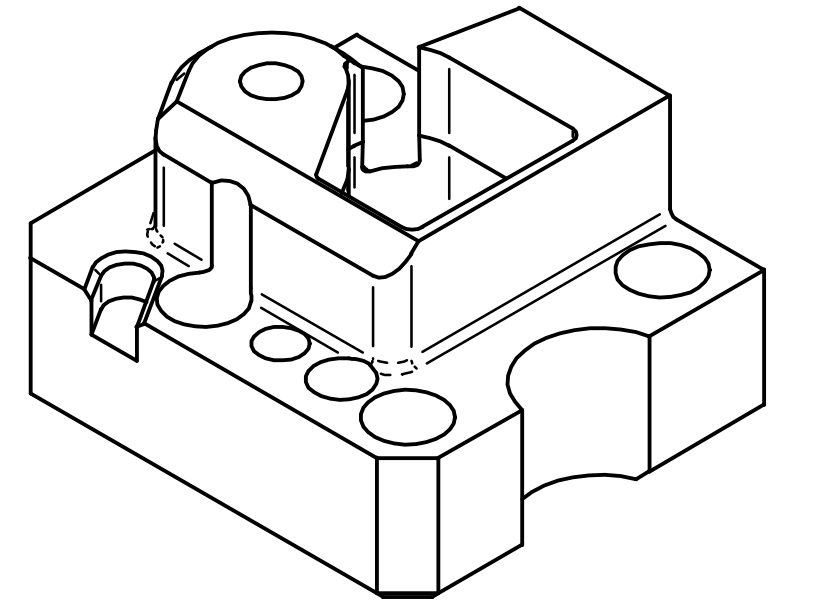
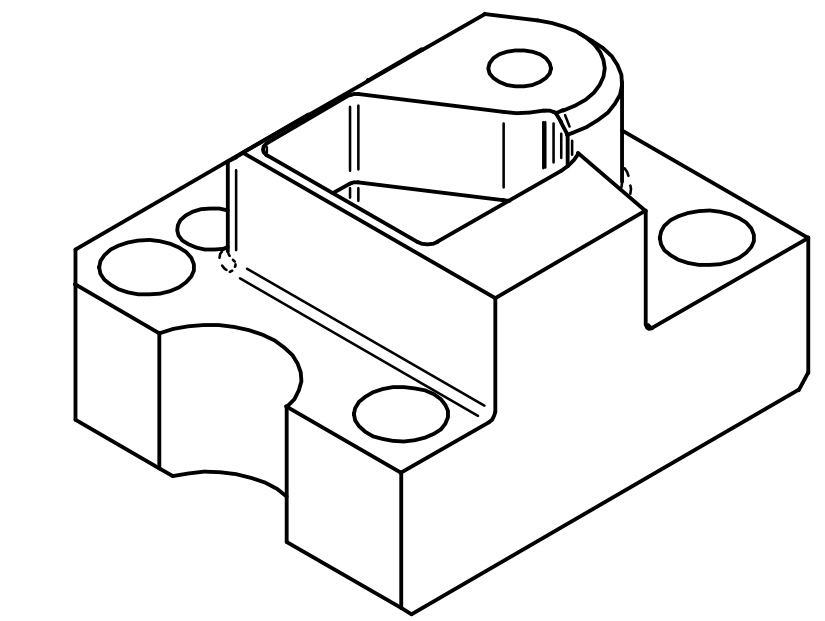
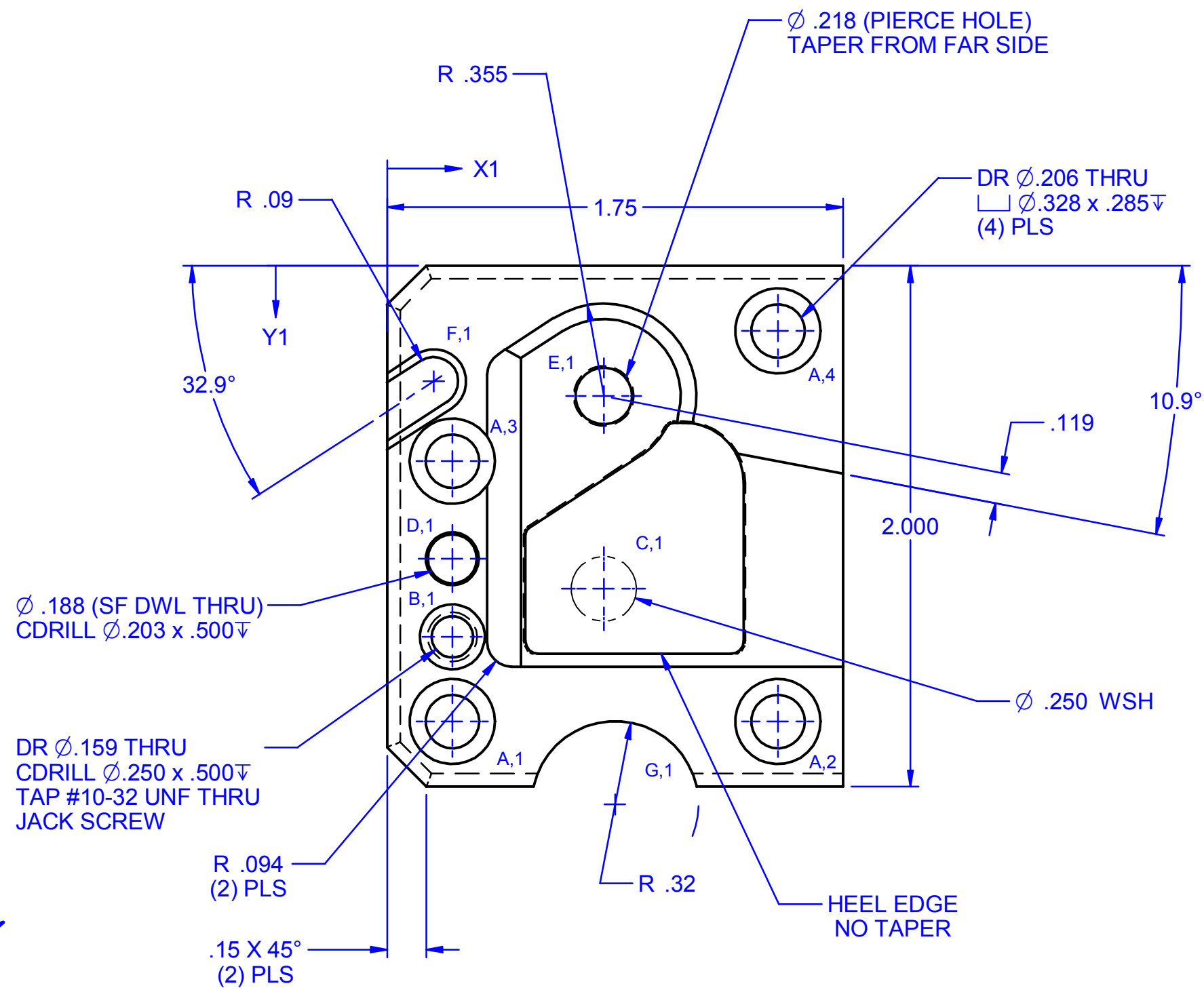

VIEW B

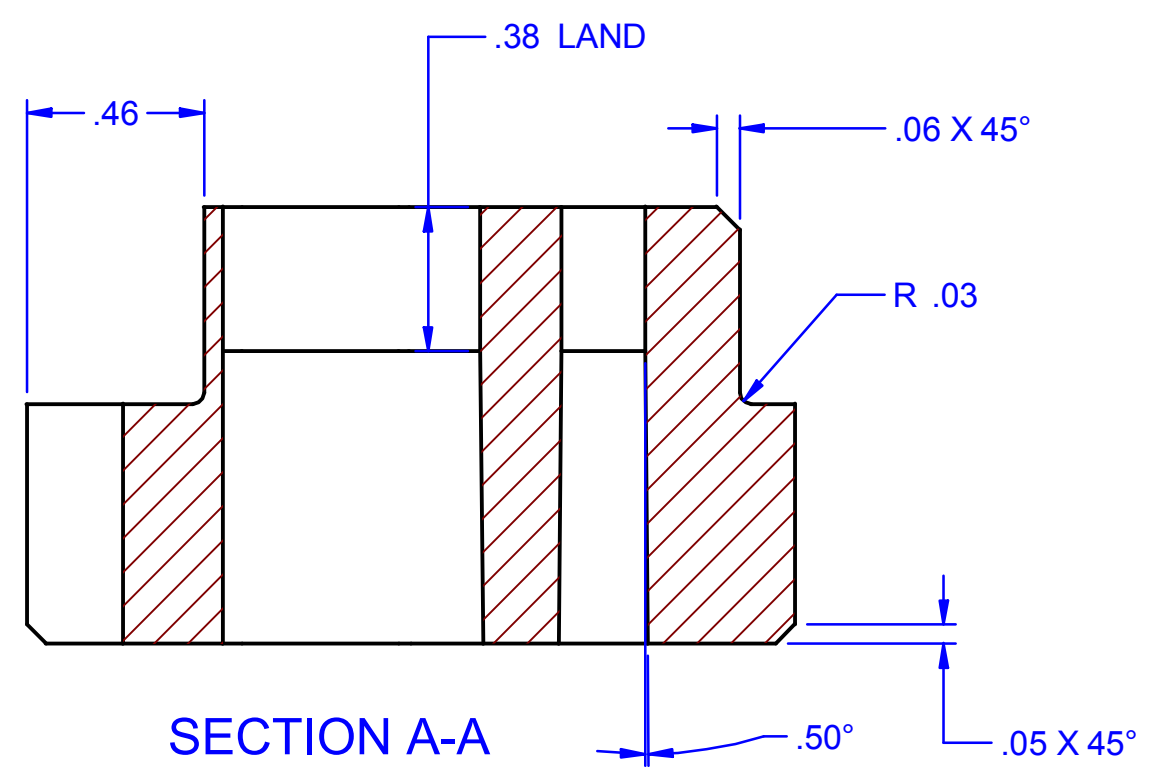
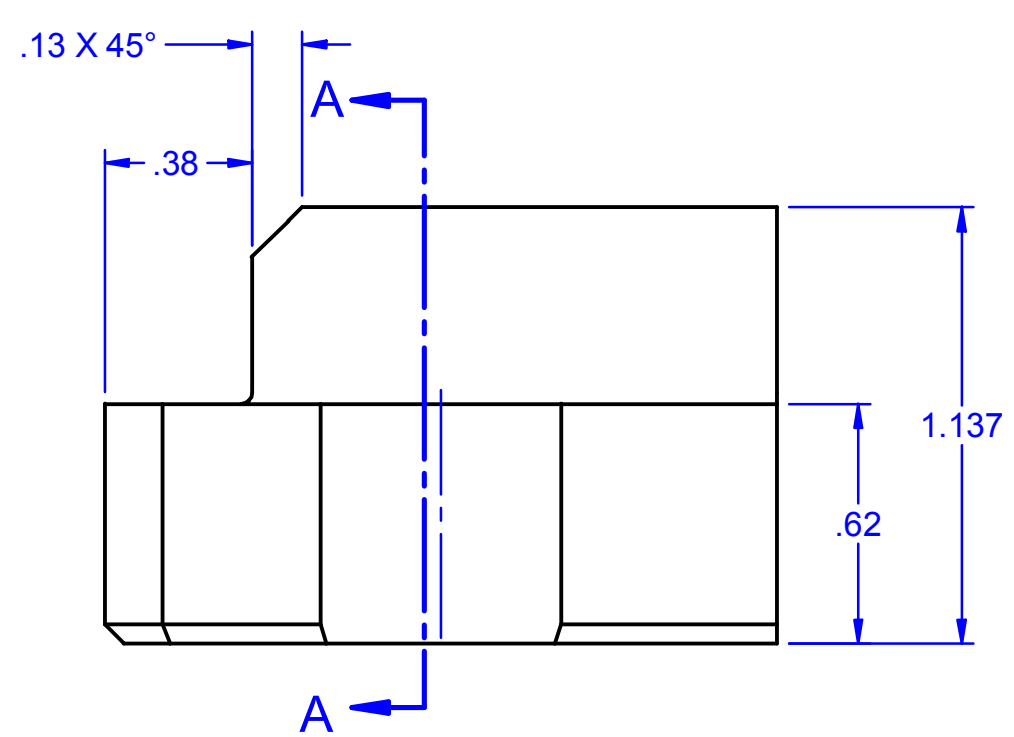

SECTION A-A

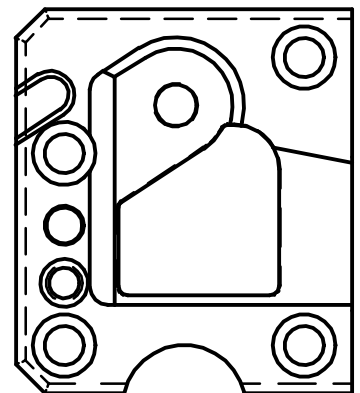

ACTUAL SIZE

<b>CONTENTS:</b> <b>2637_DB13</b> <b>DIE BLOCK - TRIM INSERT</b> ..		XYZ SIZE -- (X) 1.75 x (Y) 2.00 x (Z) 1.14 MATL -- A-2 MASS -- 0.54 LBS   DENSITY = 0.3 HT TR -- 59-61Rc ORDER No. -- VENDOR --	
DETAILED <b>8/29/2002</b>	LAST SAVE <b>8/29/2002</b>	TOLERANCE UNLESS OTHERWISE SPECIFIED .0 DECIMAL ± .030 .00 DECIMAL ± .010 .000 DECIMAL ± .001 ANGULAR ± 1/2° SCREWS ± .010   DOWELS ± .0005	FILE <b>2637_db13.dft</b> SCALE <b>2 / 1 UNLESS NOTED</b> JOB No. <b>2637</b>   DETAILER <b>SRC</b> DESIGNER <b>SRC</b>   CHECKER ..
SUMMIT TOOL DESIGN WARRANTS THE DRAWING TO BE DIMENSIONALLY CORRECT. CUSTOMER SHALL DETERMINE IF THE DESIGN IS APPROPRIATE FOR THE INTENDED USE. SUMMIT TOOL DESIGN SHALL BE LIABLE SOLELY FOR DIMENSIONAL ERRORS AND SHALL NOT BE LIABLE FOR INCIDENTAL OR CONSEQUENTIAL DAMAGE.		PROJECT <b>FUEL DOOR HINGE - PROGRESSIVE DIE</b> <b>CUSTOMER P/N 93874-7S200</b>	
		TOOL NO. .. SHEET <b>1 OF 1</b>	

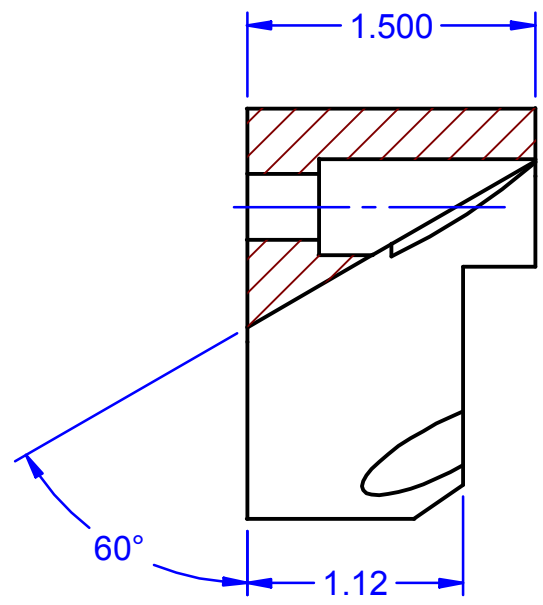

SECTION B-B

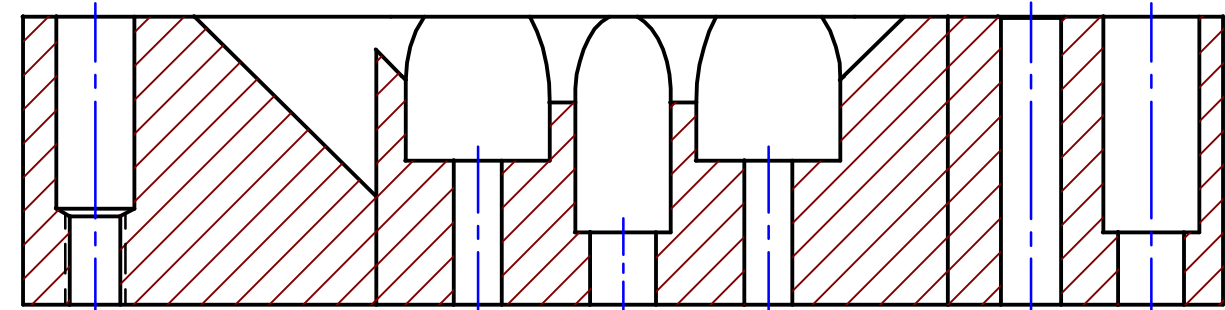
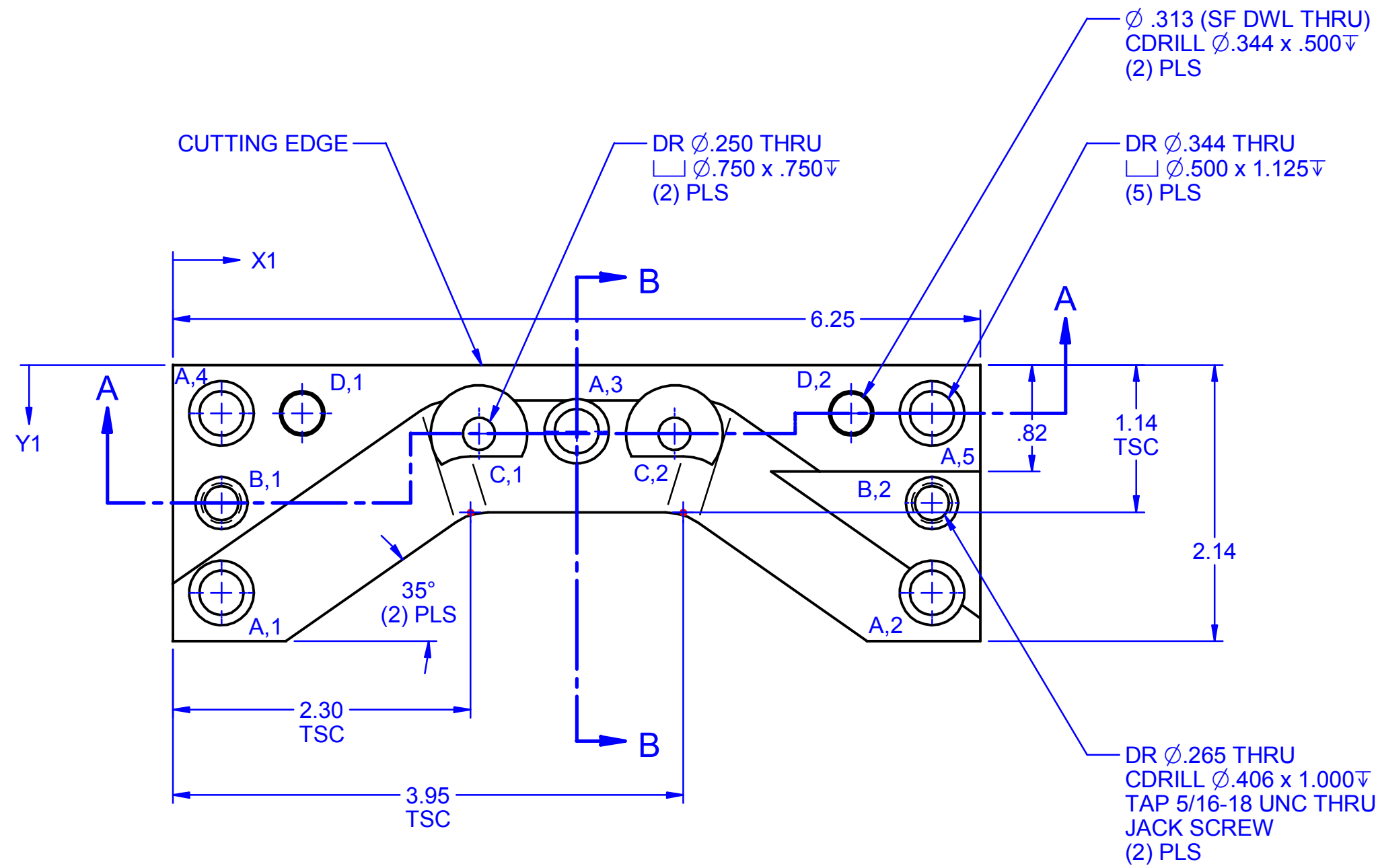

SECTION A-A

VIEW C

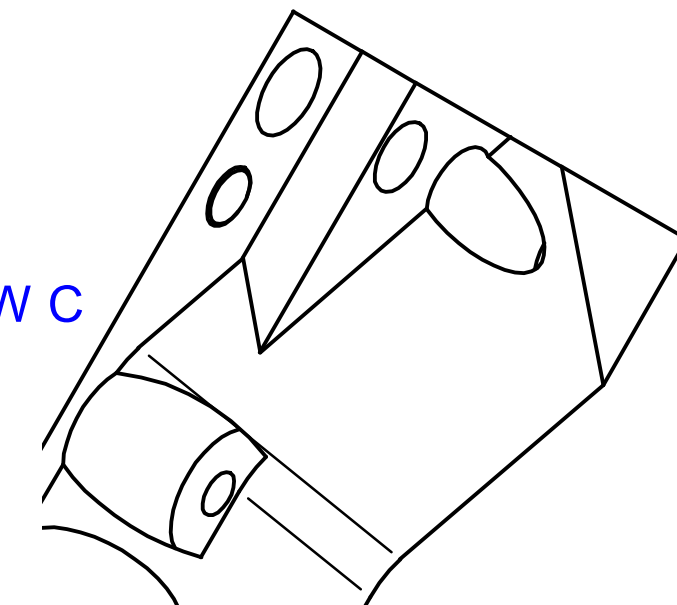

VIEW D

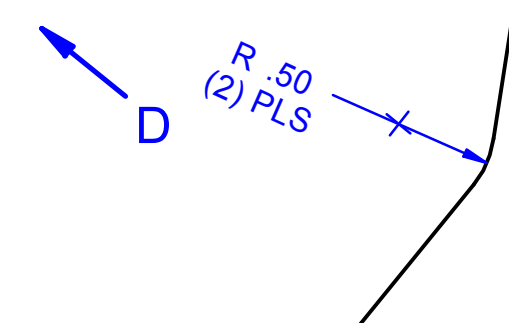

HOLE TABLE		
HOLE	X	Y
A,1	.375	-1.764
A,2	5.875	-1.764
A,3	3.125	-.514
A,4	.375	-.375
A,5	5.875	-.375
B,1	.375	-1.070
B,2	5.875	-1.070
C,1	2.369	-.533
C,2	3.881	-.533
D,1	1.000	-.375
D,2	5.250	-.375

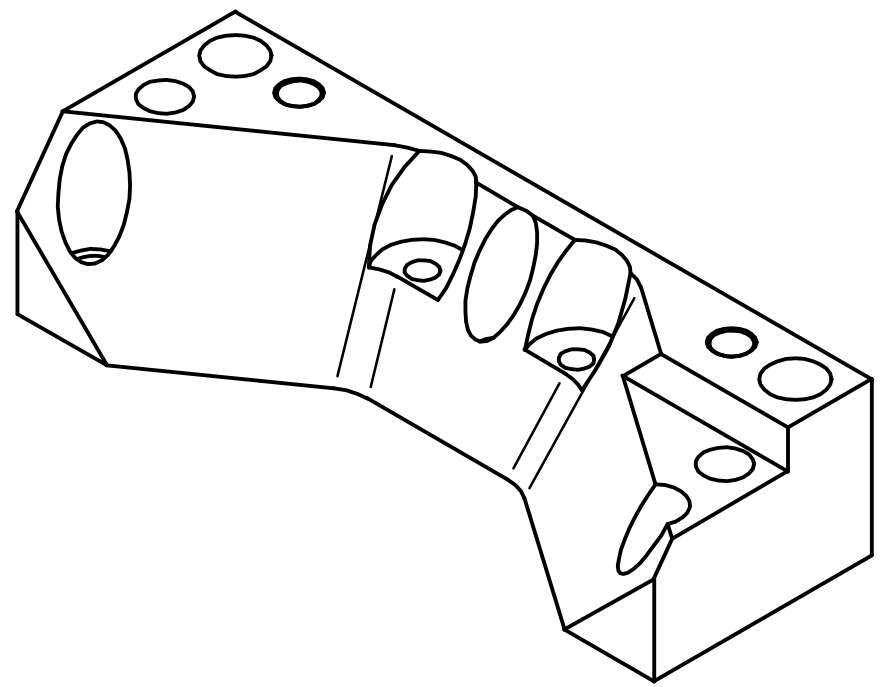

CONTENTS:

**2637\_DB15**  
**DIE BLOCK - CUTOFF**

..

XYZ SIZE -- (X) 6.25 x (Y) 2.14 x (Z) 1.50  
 MATL -- A-2  
 MASS -- 2.63 LBS | DENSITY = 0.3  
 HT TR -- 59-61Rc  
 ORDER No. --  
 VENDOR --

DETAILED 8/30/2002 LAST SAVE 8/30/2002

TOLERANCE UNLESS OTHERWISE SPECIFIED  
 .0 DECIMAL ± .030  
 .00 DECIMAL ± .010  
 .000 DECIMAL ± .001  
 ANGULAR ± 1/2'  
 SCREWS ± .010 | DOWELS ± .0005

FILE 2637\_db15.dft  
 SCALE 1/1 UNLESS NOTED

JOB No. 2637 DESIGNER SRC  
 DETAILER SRC CHECKER ..

SUMMIT TOOL DESIGN WARRANTS THE DRAWING TO BE DIMENSIONALLY CORRECT. CUSTOMER SHALL DETERMINE IF THE DESIGN IS APPROPRIATE FOR THE INTENDED USE.

SUMMIT TOOL DESIGN SHALL BE LIABLE SOLELY FOR DIMENSIONAL ERRORS AND SHALL NOT BE LIABLE FOR INCIDENTAL OR CONSEQUENTIAL DAMAGE.

PROJECT FUEL DOOR HINGE - PROGRESSIVE DIE  
 CUSTOMER P/N 93874-7S200



TOOL NO. ..  
 SHEET 1 OF 1

HOLE TABLE		
HOLE	X	Y
A,1	.375	-2.125
A,2	3.625	-2.125
A,3	.375	-.375
A,4	3.625	-.375
B,1	.375	-1.500
B,2	3.625	-1.500
C,1	.375	-.875
C,2	3.625	-.875

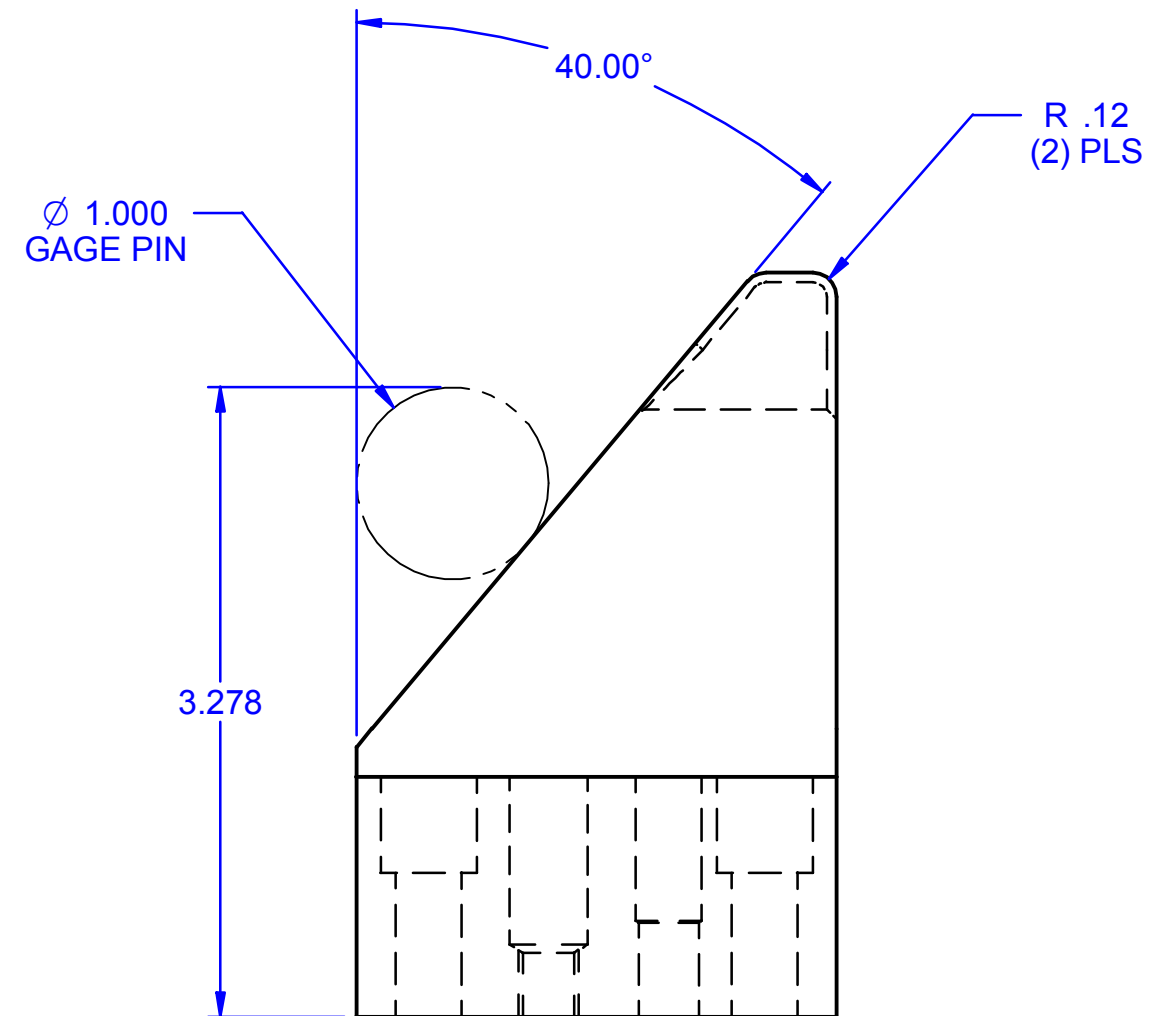
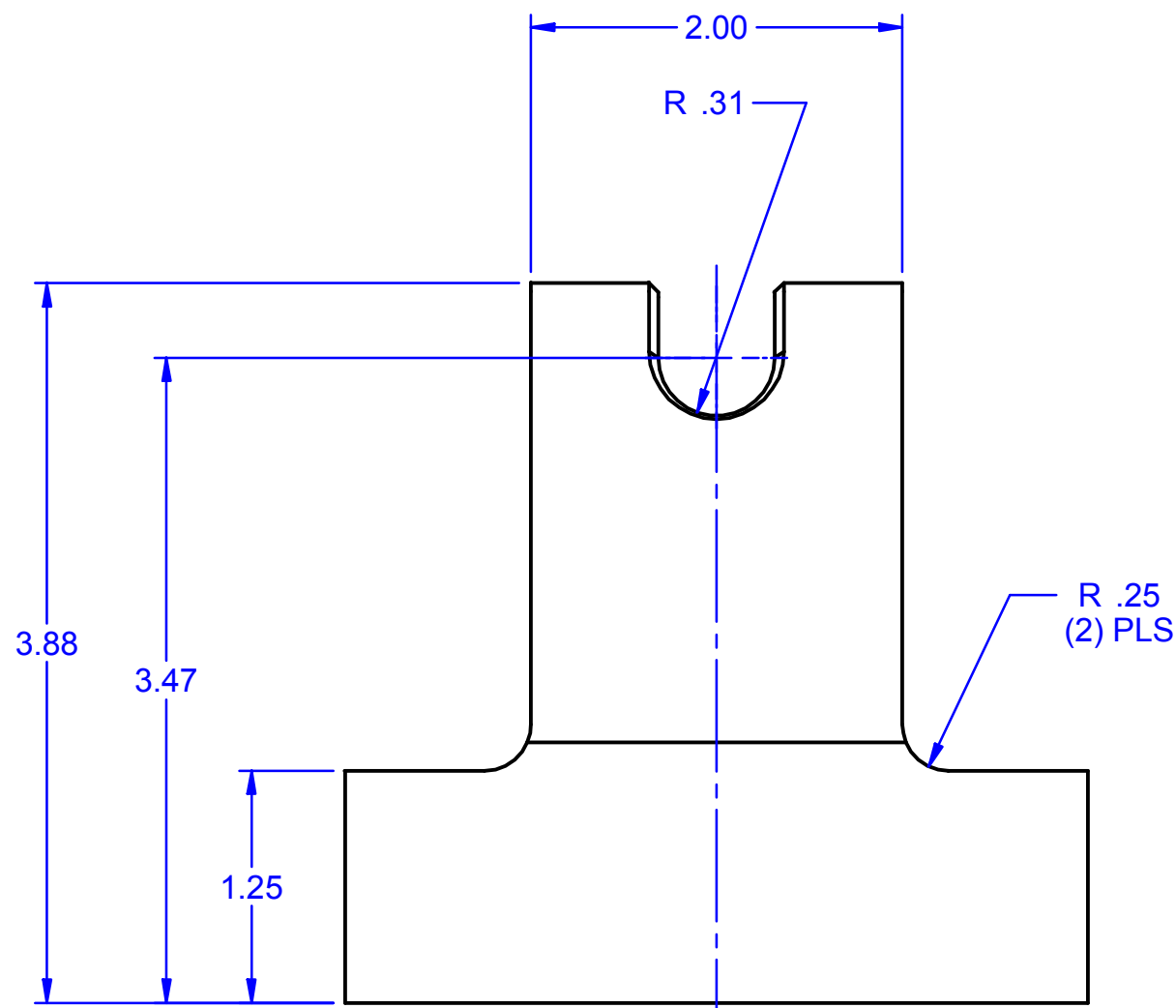
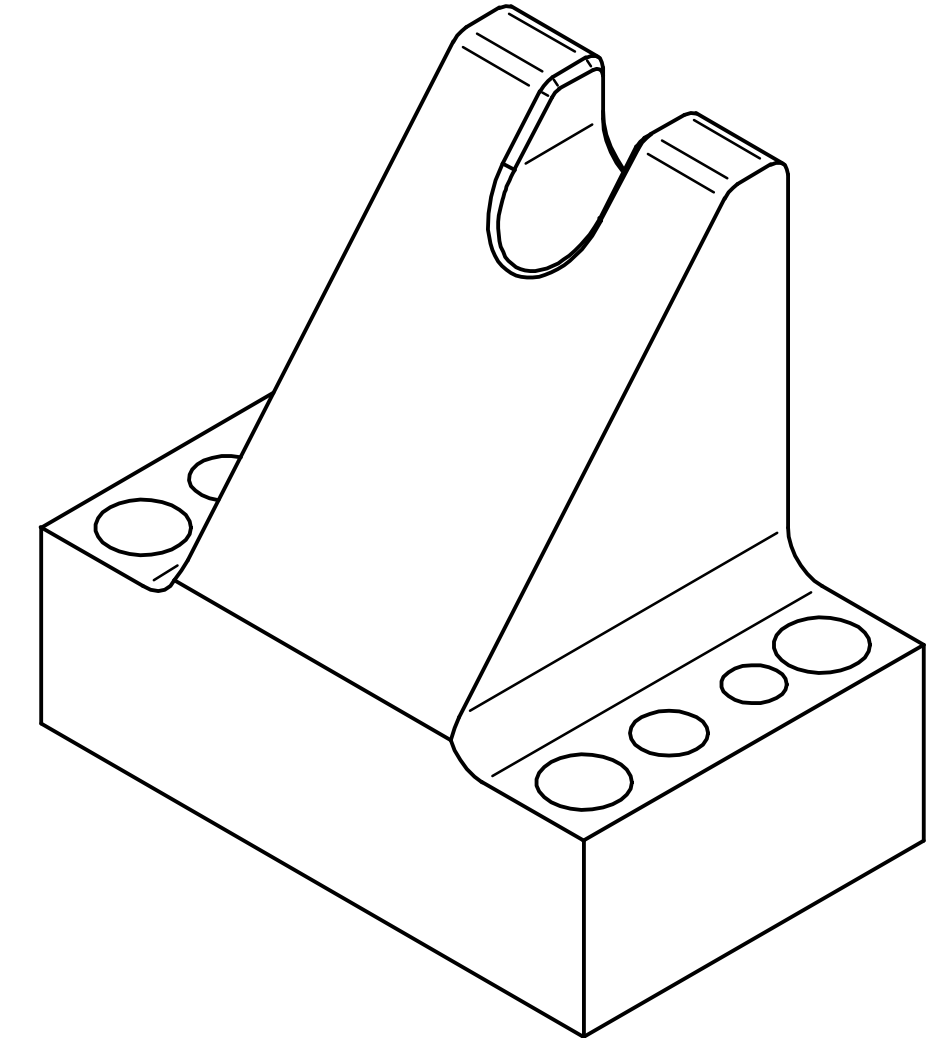
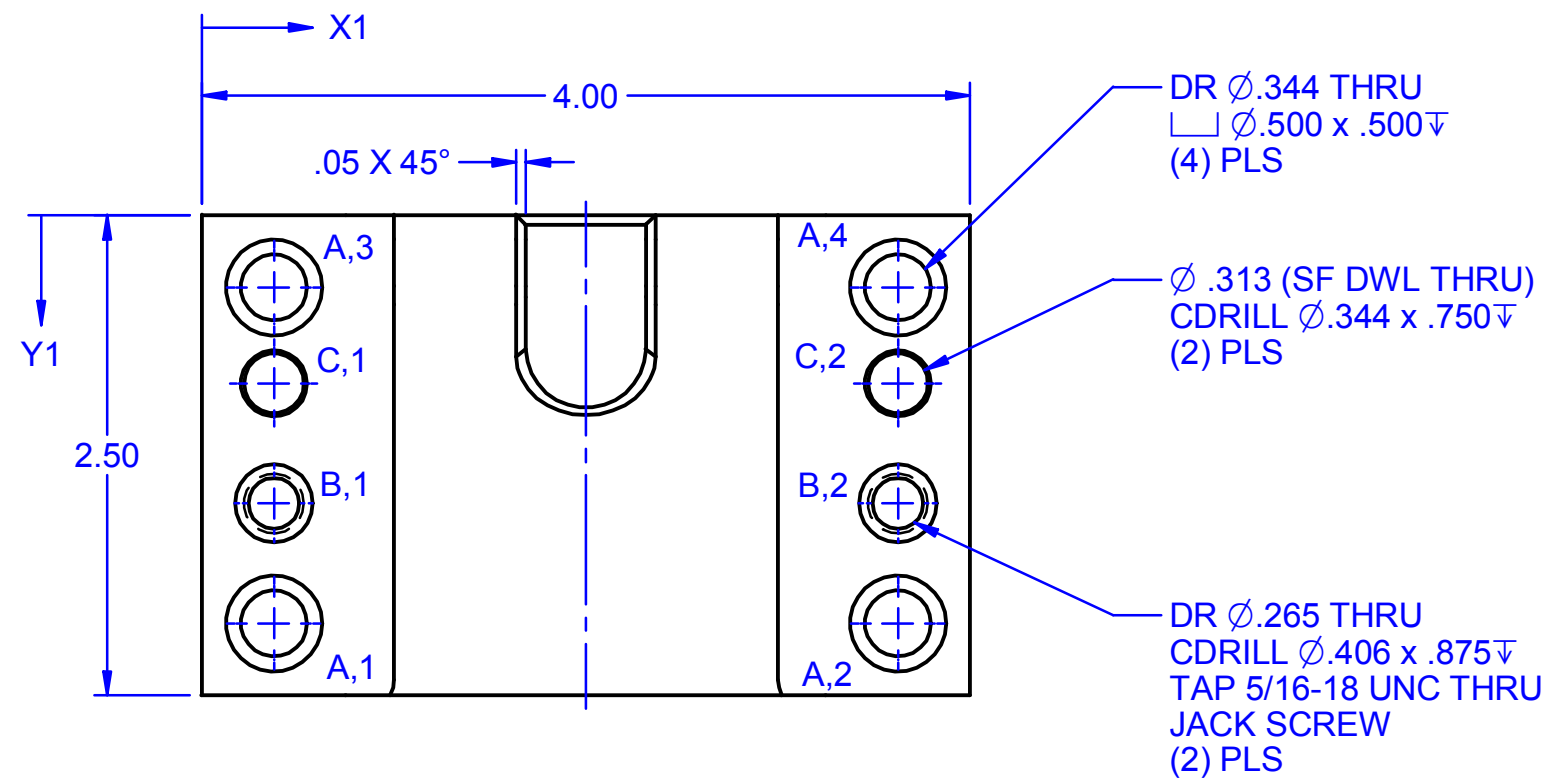

**CONTENTS:**  
**2637\_F1C25**  
**SLIDE DRIVER**

XYZ SIZE -- (X) 4.00 x (Y) 2.50 x (Z) 3.87  
 MATL -- S-7  
 MASS -- 5.42 LBS | DENSITY = 0.3  
 HT TR -- 56-58Rc  
 ORDER No. --  
 VENDOR --

DETAILED 9/5/2002 LAST SAVE 9/5/2002

TOLERANCE UNLESS OTHERWISE SPECIFIED

FILE 2637\_f1c25.dft

SCALE 1/1 UNLESS NOTED

SUMMIT TOOL DESIGN WARRANTS THE DRAWING TO BE DIMENSIONALLY CORRECT. CUSTOMER SHALL DETERMINE IF THE DESIGN IS APPROPRIATE FOR THE INTENDED USE.

.0 DECIMAL  $\pm$  .030  
 .00 DECIMAL  $\pm$  .010  
 .000 DECIMAL  $\pm$  .001  
 ANGULAR  $\pm$  1/2'  
 SCREWS  $\pm$  .010 | DOWELS  $\pm$  .0005

JOB No. 2637

DETAILER SRC

DESIGNER SRC

CHECKER ..

SUMMIT TOOL DESIGN SHALL BE LIABLE SOLELY FOR DIMENSIONAL ERRORS AND SHALL NOT BE LIABLE FOR INCIDENTAL OR CONSEQUENTIAL DAMAGE.

PROJECT **FUEL DOOR HINGE - PROGRESSIVE DIE**  
**CUSTOMER P/N 93874-7S200**



TOOL NO. ..  
 SHEET 1 OF 1

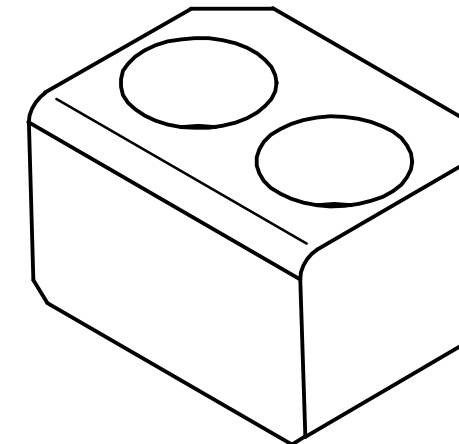
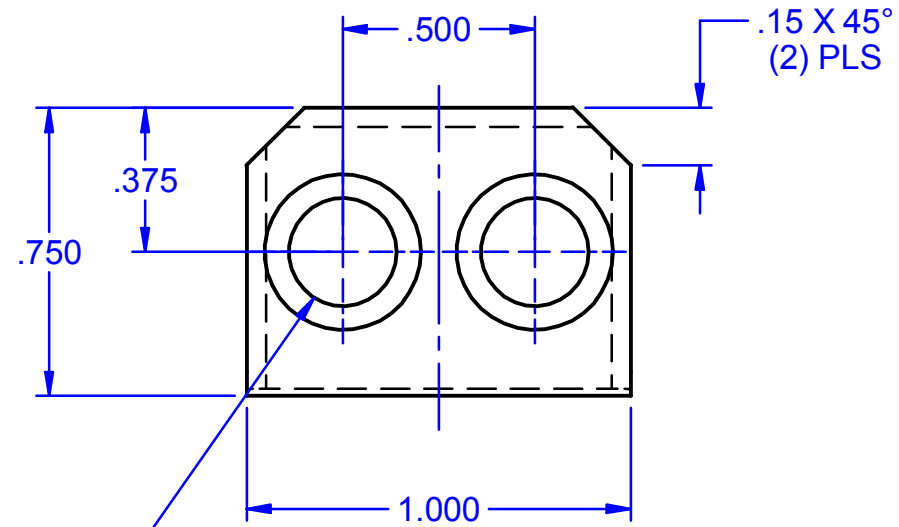

DR Ø.281 THRU  
 □ Ø.406 x .280▽  
 (2) PLS

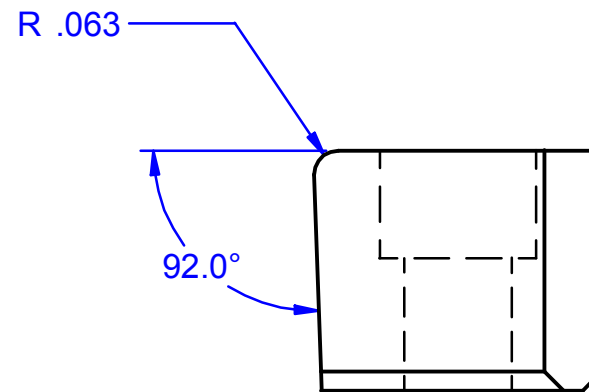
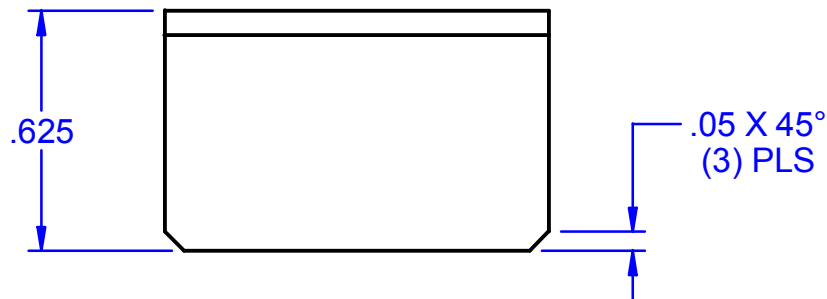

**CONTENTS:**  
**2637\_FD01**  
**FORM DIE INSERT**  
 ..

**XYZ SIZE -- (X) 1.00 x (Y) .75 x (Z) .62**  
**MATL -- D-2**  
**MASS -- 0.09 LBS | DENSITY = 0.3**  
**HT TR -- 59-61Rc**  
**ORDER No. --**  
**VENDOR --**

DETAILED **9/5/2002** | LAST SAVE **9/5/2002**

SUMMIT TOOL DESIGN WARRANTS THE DRAWING TO BE DIMENSIONALLY CORRECT. CUSTOMER SHALL DETERMINE IF THE DESIGN IS APPROPRIATE FOR THE INTENDED USE.

SUMMIT TOOL DESIGN SHALL BE LIABLE SOLELY FOR DIMENSIONAL ERRORS AND SHALL NOT BE LIABLE FOR INCIDENTAL OR CONSEQUENTIAL DAMAGE.

TOLERANCE UNLESS OTHERWISE SPECIFIED  
 .0 DECIMAL ± .030  
 .00 DECIMAL ± .010  
 .000 DECIMAL ± .001  
 ANGULAR ± 1/2°  
 SCREWS ± .010 | DOWELS ± .0005

PROJECT **FUEL DOOR HINGE - PROGRESSIVE DIE**  
**CUSTOMER P/N 93874-7S200**

FILE **2637\_fd01.dft**  
 SCALE **2 / 1 UNLESS NOTED**  
 JOB No. **2637** | DESIGNER **SRC**  
 DETAILER **SRC** | CHECKER **..**



TOOL NO. **..**  
 SHEET **1 OF 1**

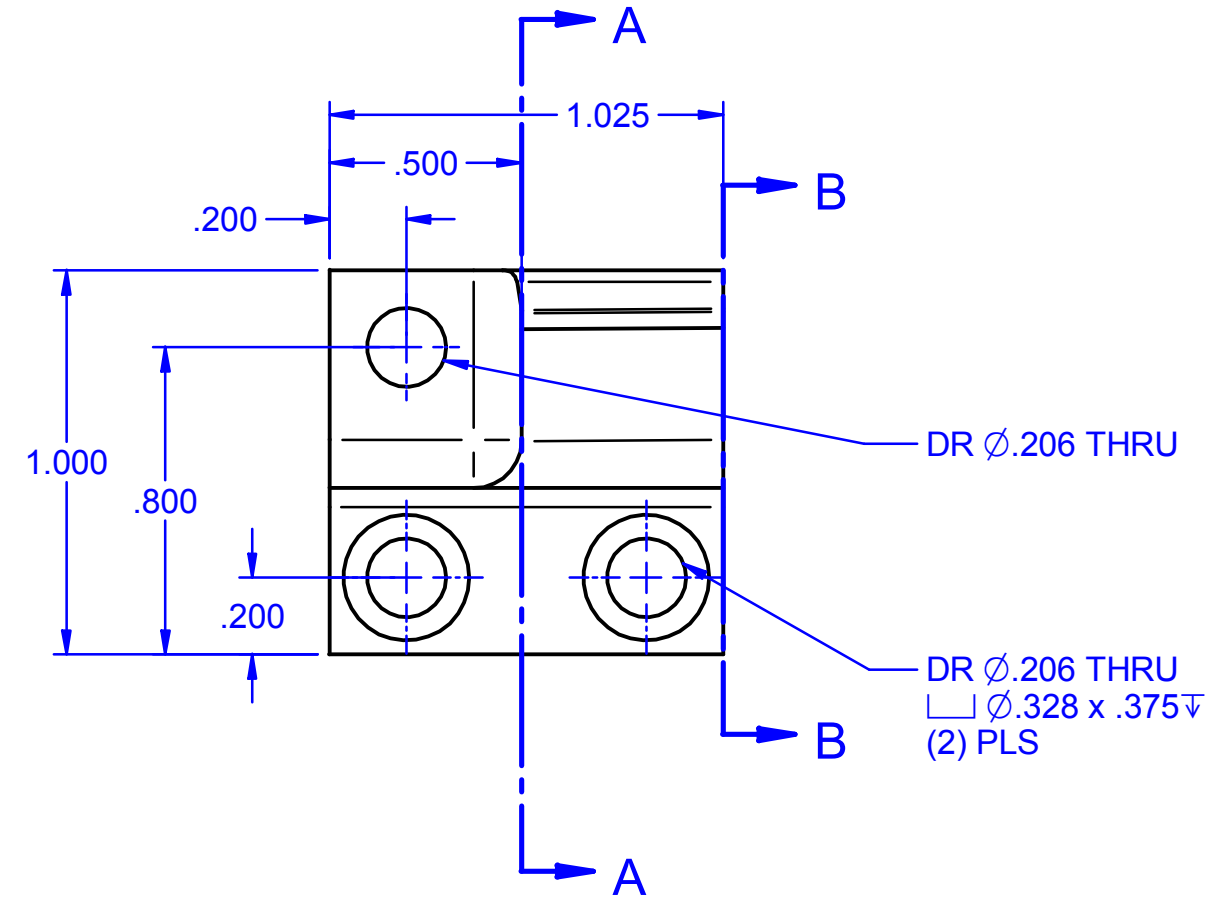
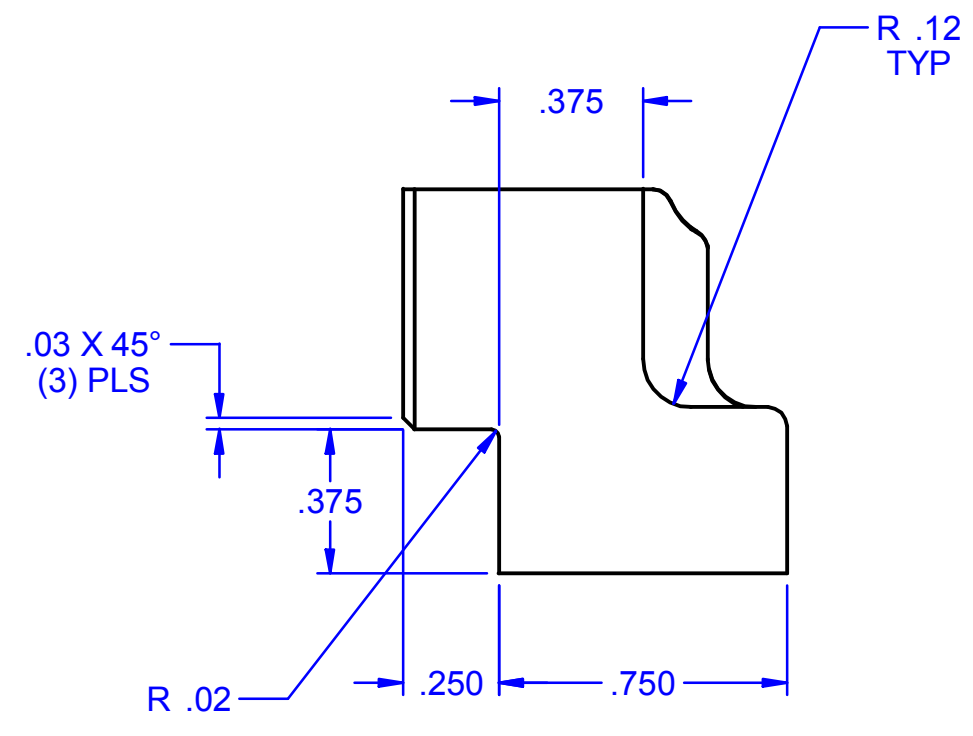
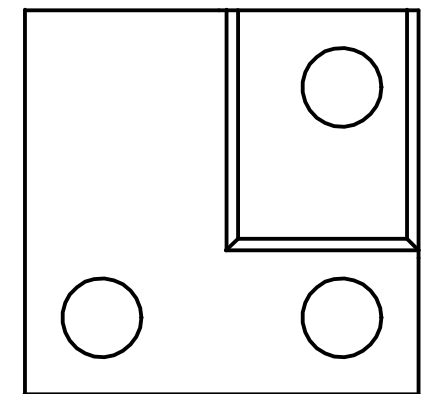
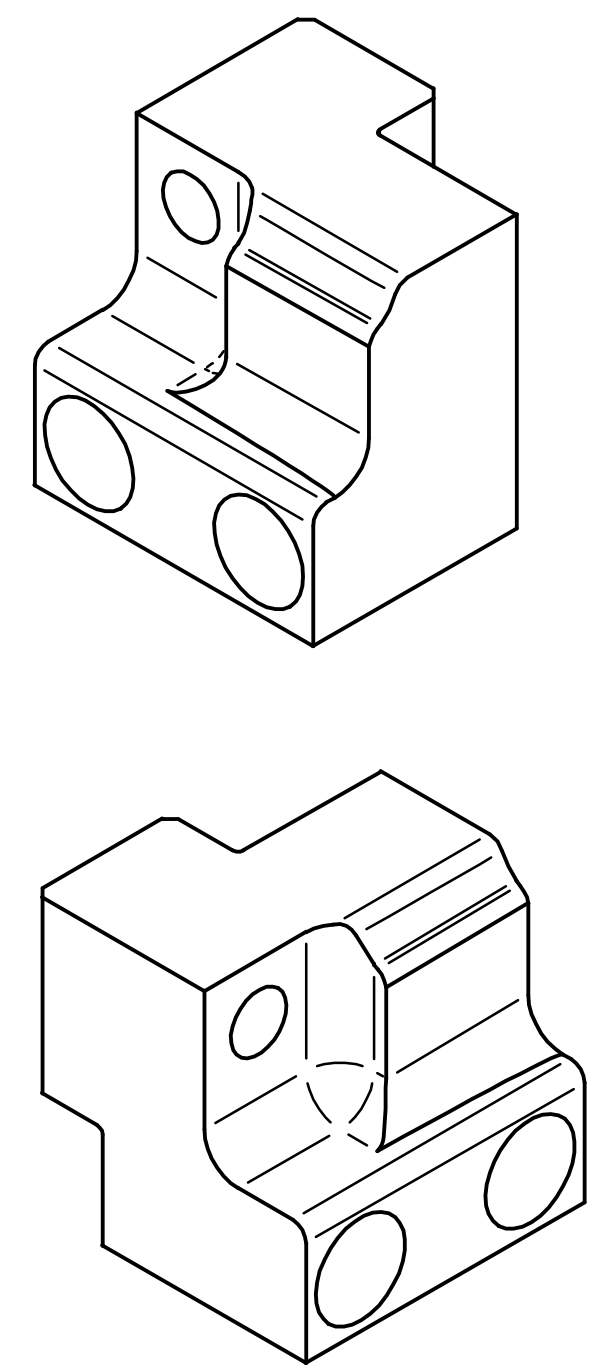
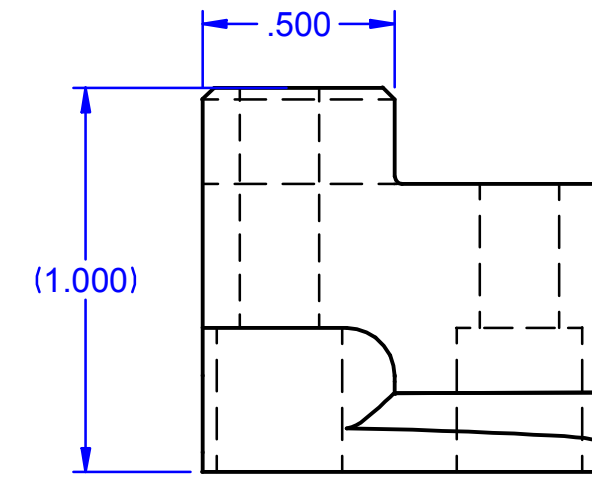
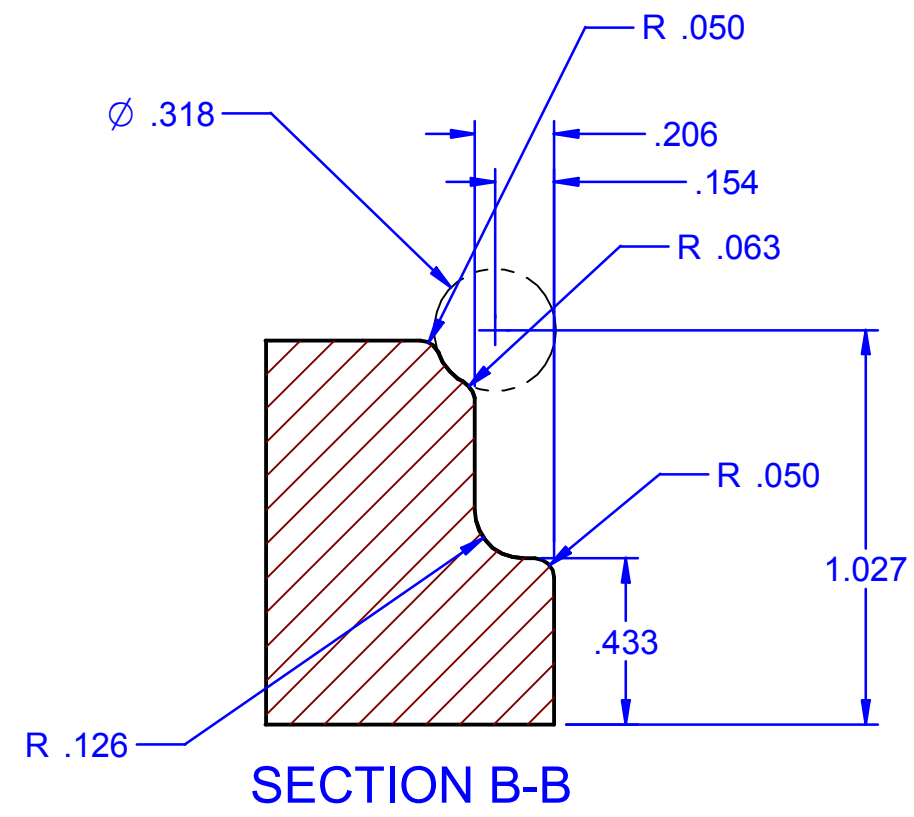
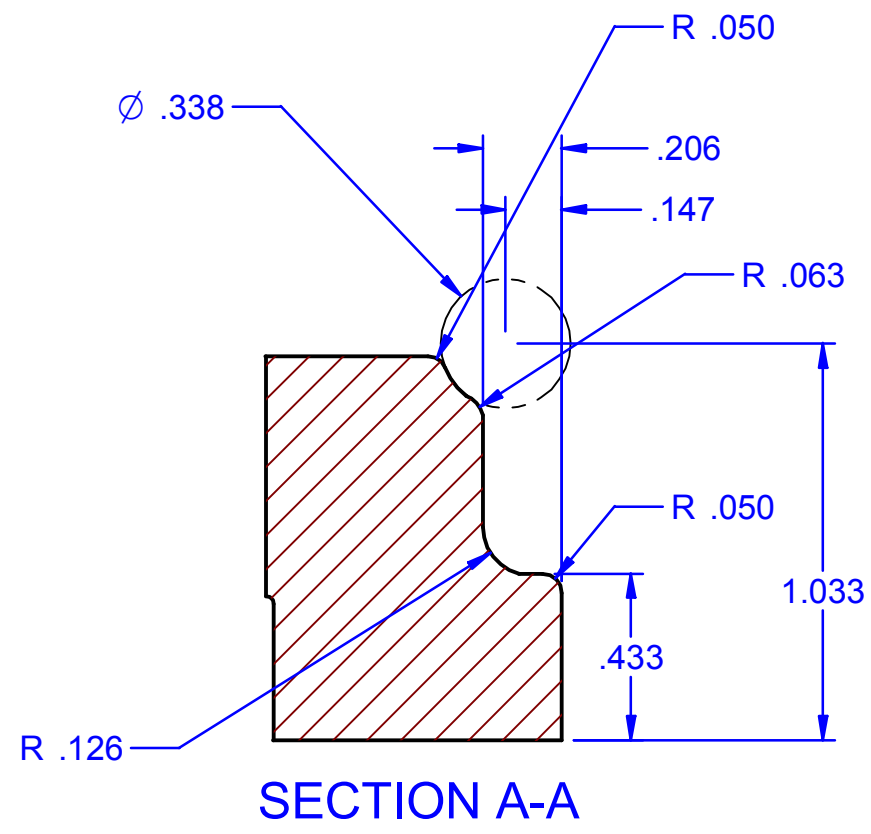

<b>CONTENTS:</b> <b>2637_FD02</b> <b>FORM DIE INSERT</b> ..		XYZ SIZE -- (X) 1.03 x (Y) 1.00 x (Z) 1.00 MATL -- D-2 MASS -- 0.16 LBS   DENSITY = 0.3 HT TR -- 59-61Rc ORDER No. -- VENDOR --	
DETAILED 9/6/2002	LAST SAVE 9/6/2002	TOLERANCE UNLESS OTHERWISE SPECIFIED .0 DECIMAL ± .030 .00 DECIMAL ± .010 .000 DECIMAL ± .001 ANGULAR ± 1/2° SCREWS ± .010   DOWELS ± .0005	FILE 2637_fd02.dft SCALE 2 / 1 UNLESS NOTED JOB No. 2637 DESIGNER SRC DETAILER SRC CHECKER ..
SUMMIT TOOL DESIGN WARRANTS THE DRAWING TO BE DIMENSIONALLY CORRECT. CUSTOMER SHALL DETERMINE IF THE DESIGN IS APPROPRIATE FOR THE INTENDED USE. SUMMIT TOOL DESIGN SHALL BE LIABLE SOLELY FOR DIMENSIONAL ERRORS AND SHALL NOT BE LIABLE FOR INCIDENTAL OR CONSEQUENTIAL DAMAGE.		PROJECT <b>FUEL DOOR HINGE - PROGRESSIVE DIE</b> <b>CUSTOMER P/N 93874-7S200</b>	
		TOOL NO. .. SHEET <b>1 OF 1</b>	

HOLE	X	Y
A,1	2.000	-.375
B,1	.375	-2.875
B,2	6.625	-2.875
B,3	3.500	-1.625
B,4	.375	-.375
B,5	6.625	-.375
C,1	3.550	-2.737
C,2	4.050	-2.737
D,1	5.500	-2.375
D,2	.925	-2.375
E,1	4.550	-2.100
F,1	1.250	-.375
G,1	.925	-1.125
G,2	5.925	-1.125
H,1	5.950	-2.775
H,2	1.373	-3.000

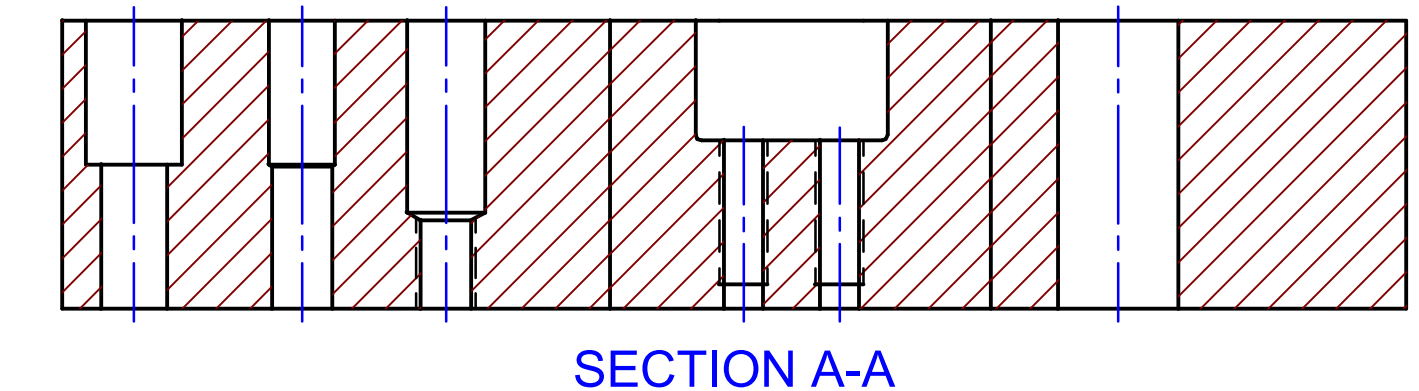
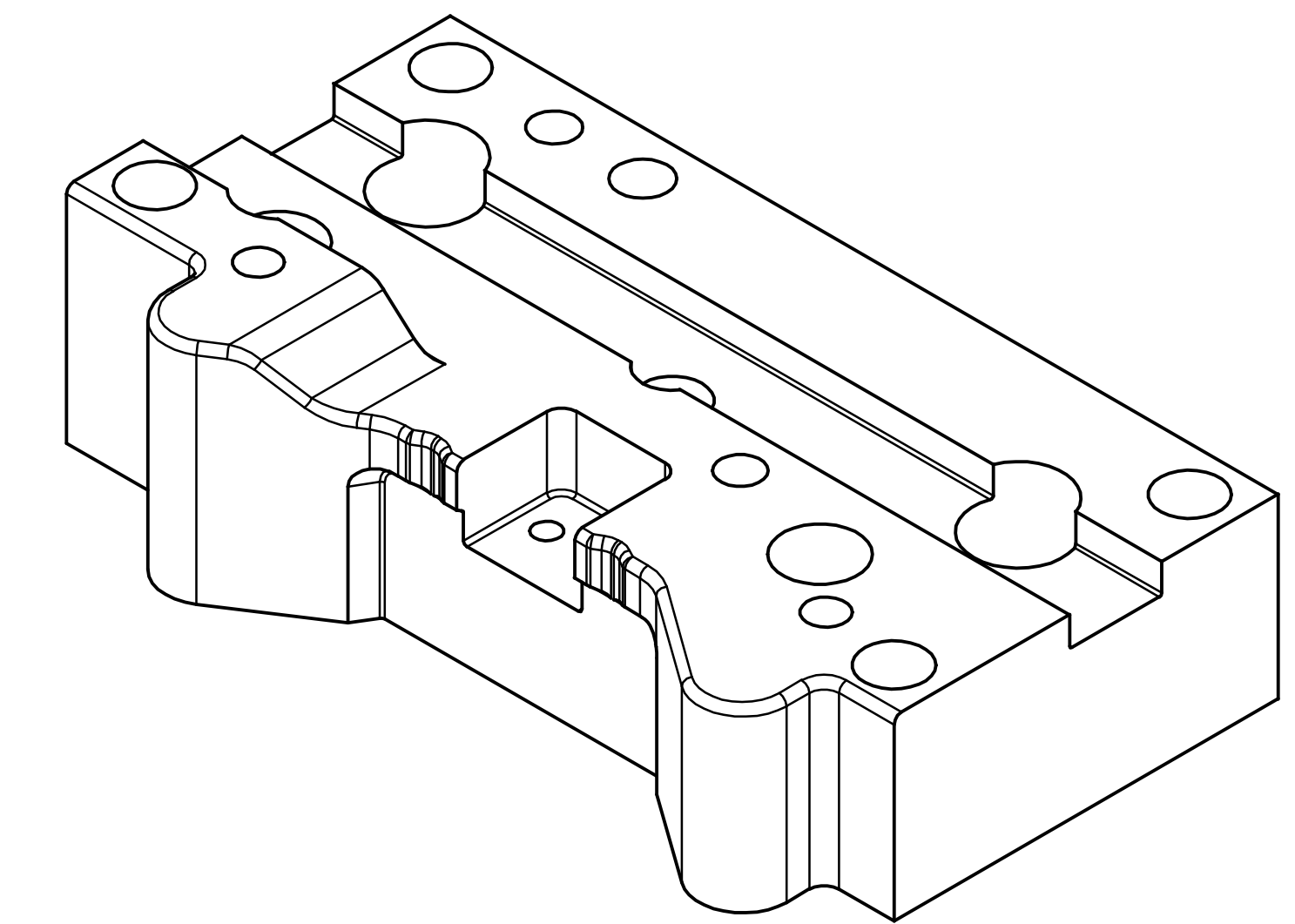
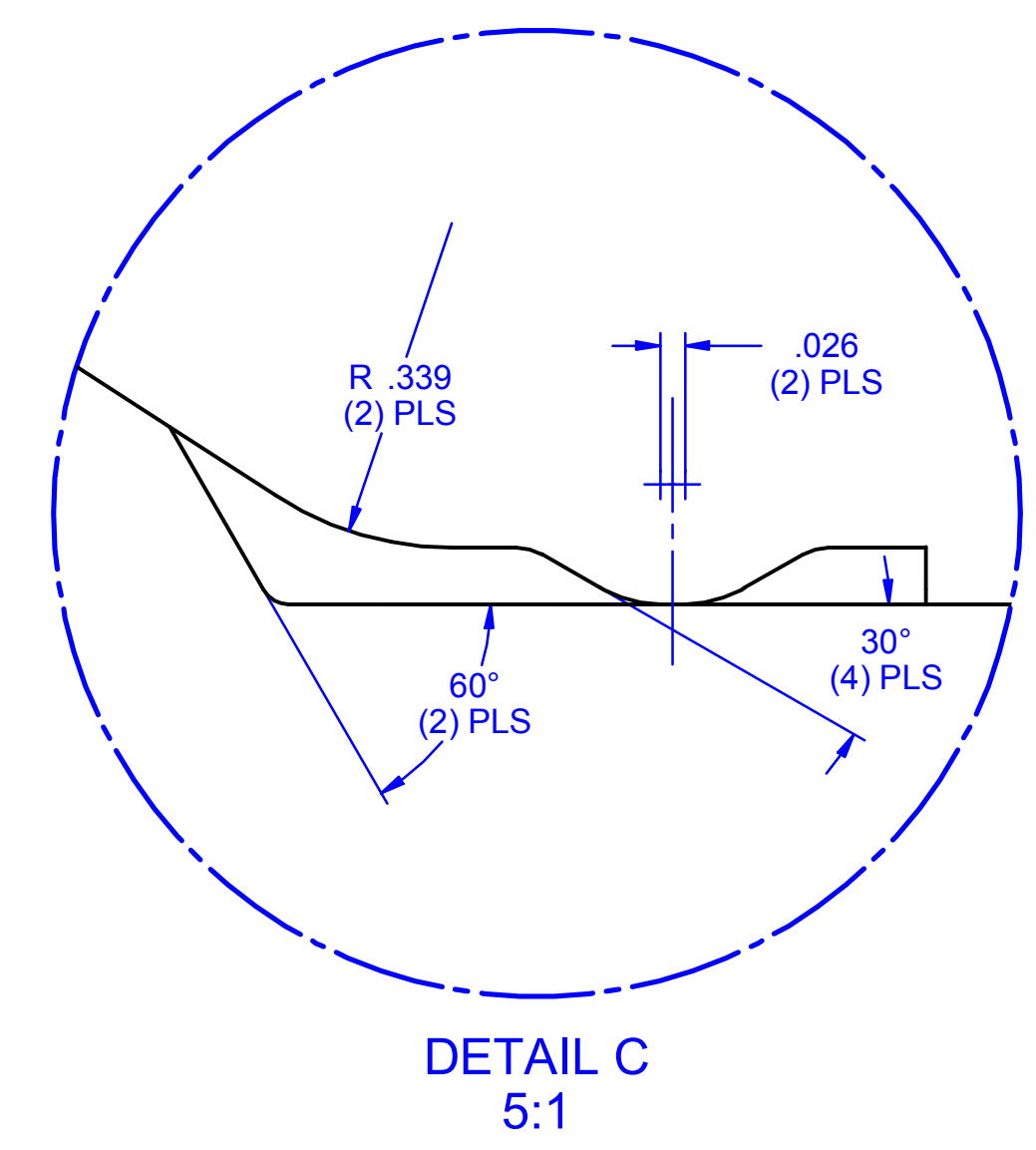
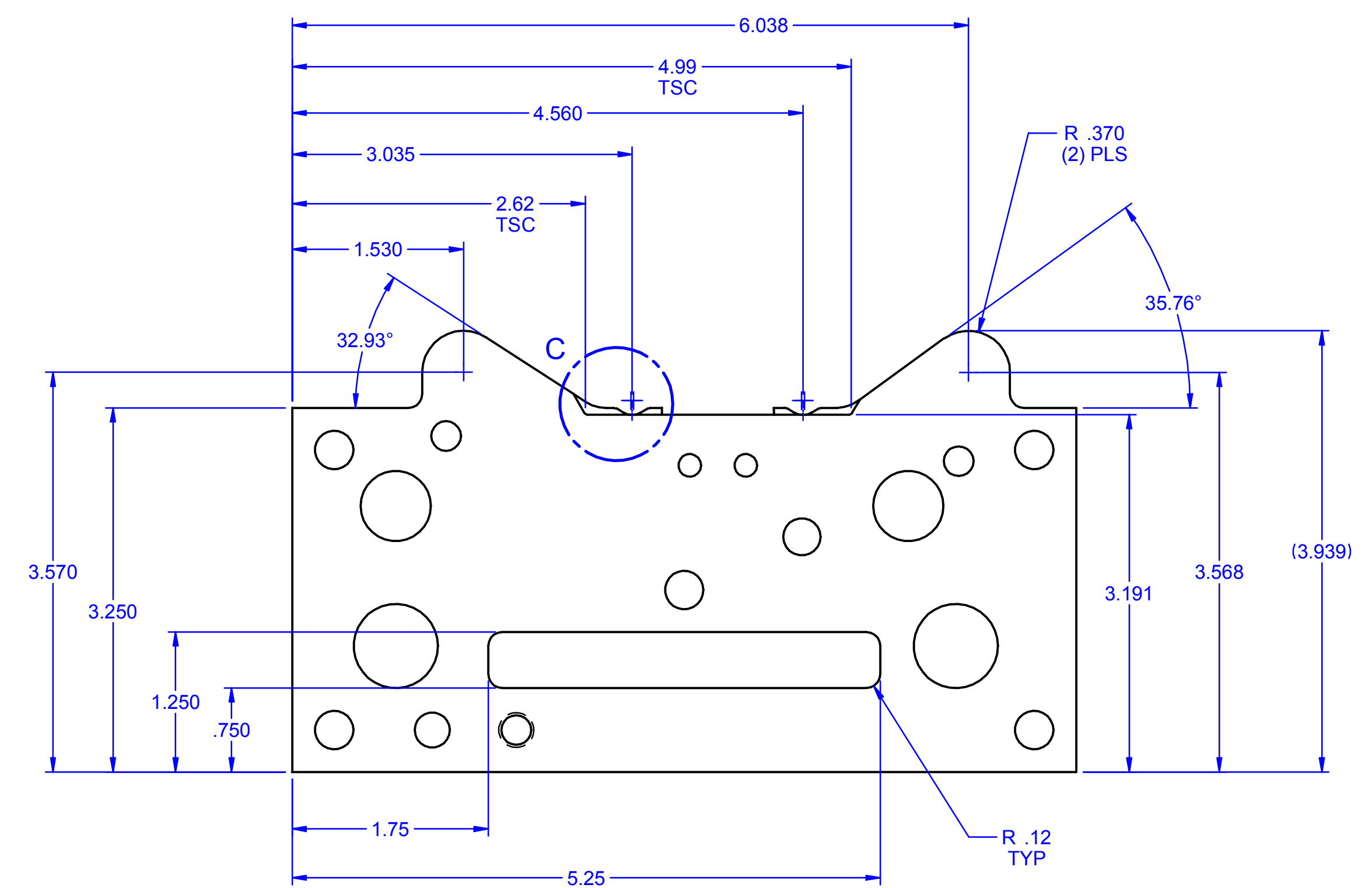
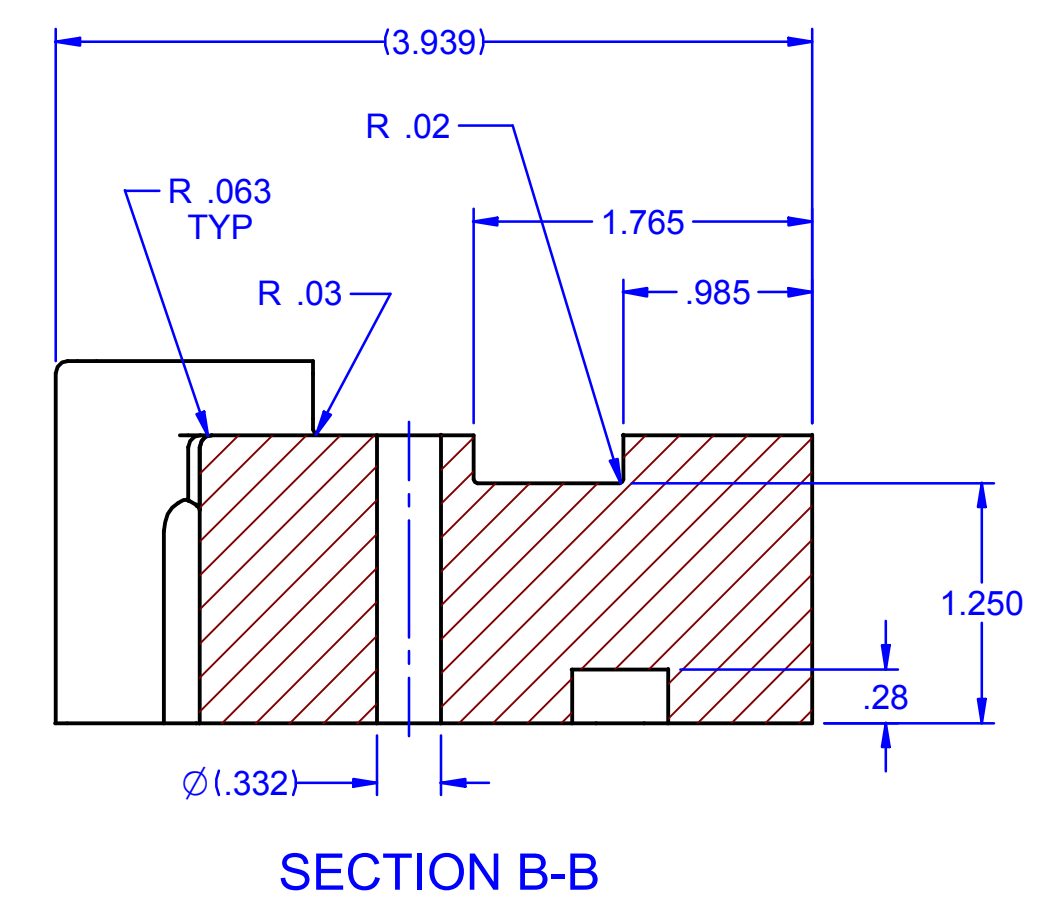
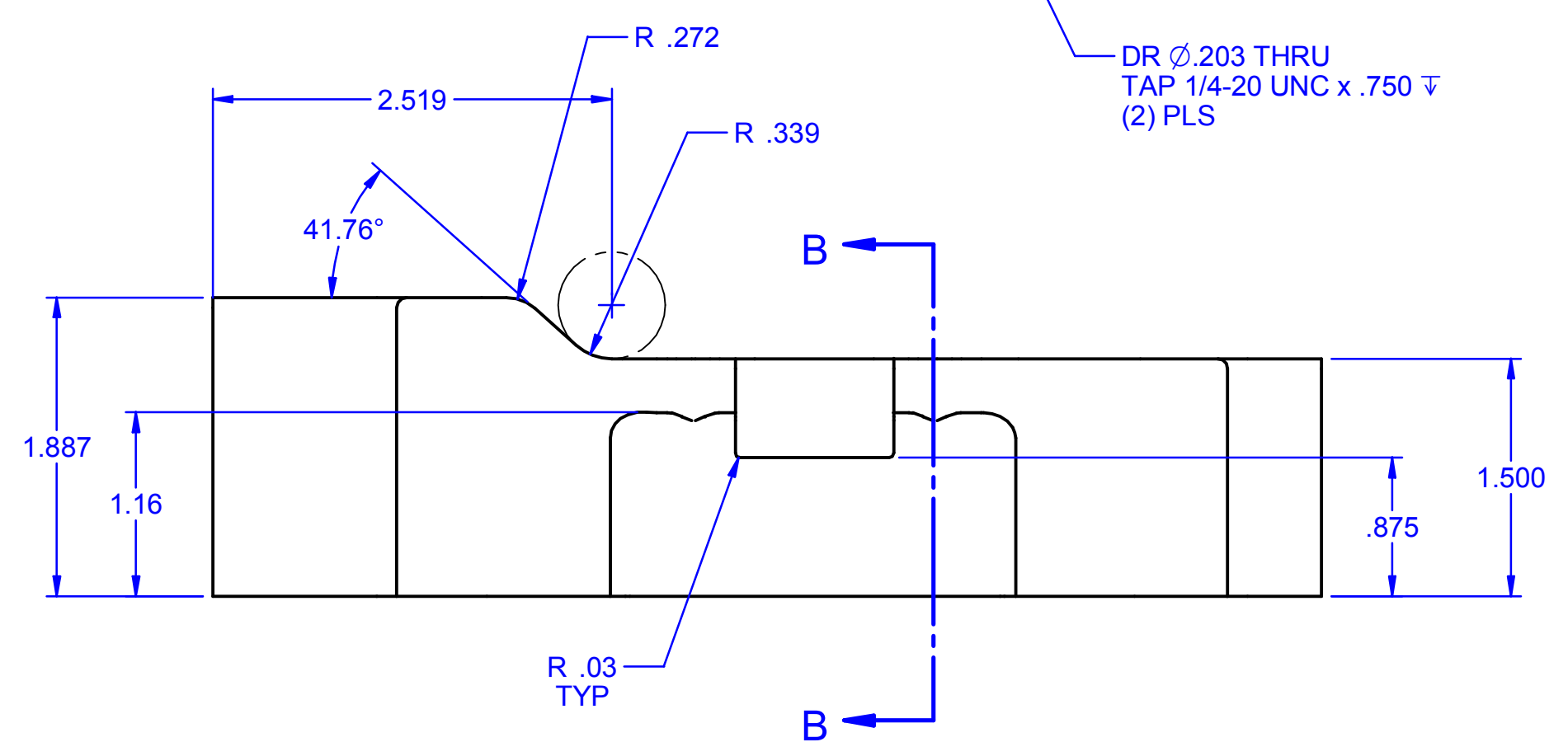
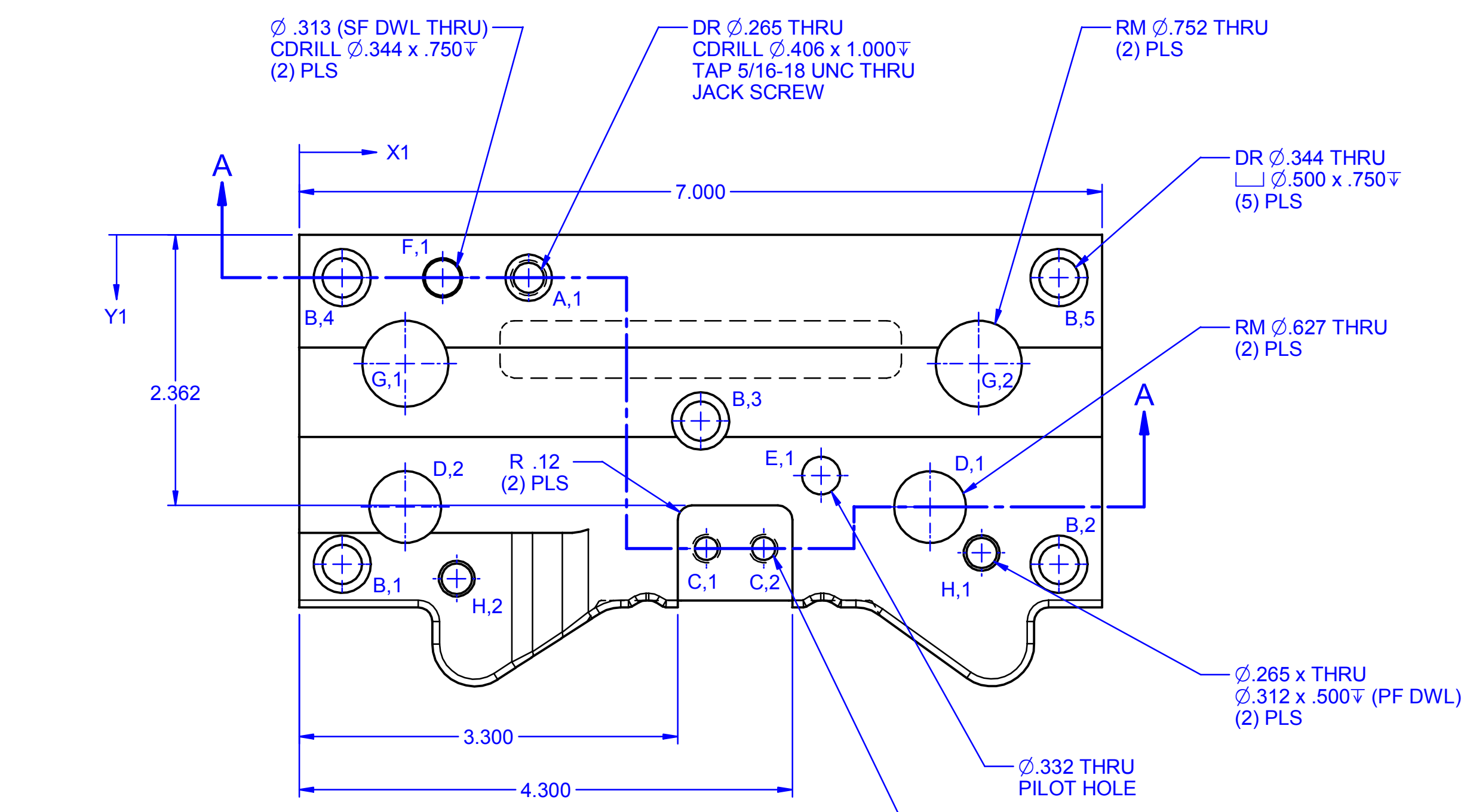

<b>CONTENTS:</b>		XYZ SIZE -- (X) 7.00 x (Y) 4.25 x (Z) 1.89	
2637_FDB02		MATL -- D-2	
DIE BLOCK - FORMING		MASS -- 8.61 LBS   DENSITY = 0.3	
..		HT TR -- 59-61Rc	
..		ORDER No. --	
..		VENDOR --	
DETAILED 9/7/2002	LAST SAVE 9/7/2002	TOLERANCE UNLESS OTHERWISE SPECIFIED 0.00 DECIMAL ± .000 .00 DECIMAL ± .010 .000 DECIMAL ± .001 ANGULAR ± 1/2° SCREWS ± .010   DOWELS ± .0005	FILE 2637_fdb02.dft SCALE 1/1 UNLESS NOTED
SUMMIT TOOL DESIGN WARRANTS THE DRAWING TO BE DIMENSIONALLY CORRECT. CUSTOMER SHALL DETERMINE IF THE DESIGN IS APPROPRIATE FOR THE INTENDED USE.		JOB No. 2637	DETAILER SRC
SUMMIT TOOL DESIGN SHALL BE LIABLE SOLELY FOR DIMENSIONAL ERRORS AND SHALL NOT BE LIABLE FOR INCIDENTAL OR CONSEQUENTIAL DAMAGE.		DESIGNER SRC	CHECKER ..
PROJECT FUEL DOOR HINGE - PROGRESSIVE DIE CUSTOMER P/N 93874-7S200			
		TOOL NO. ..	
		SHEET 1 OF 1	

DESIGN BY: SUMMIT TOOL DESIGN - www.summitedge.com

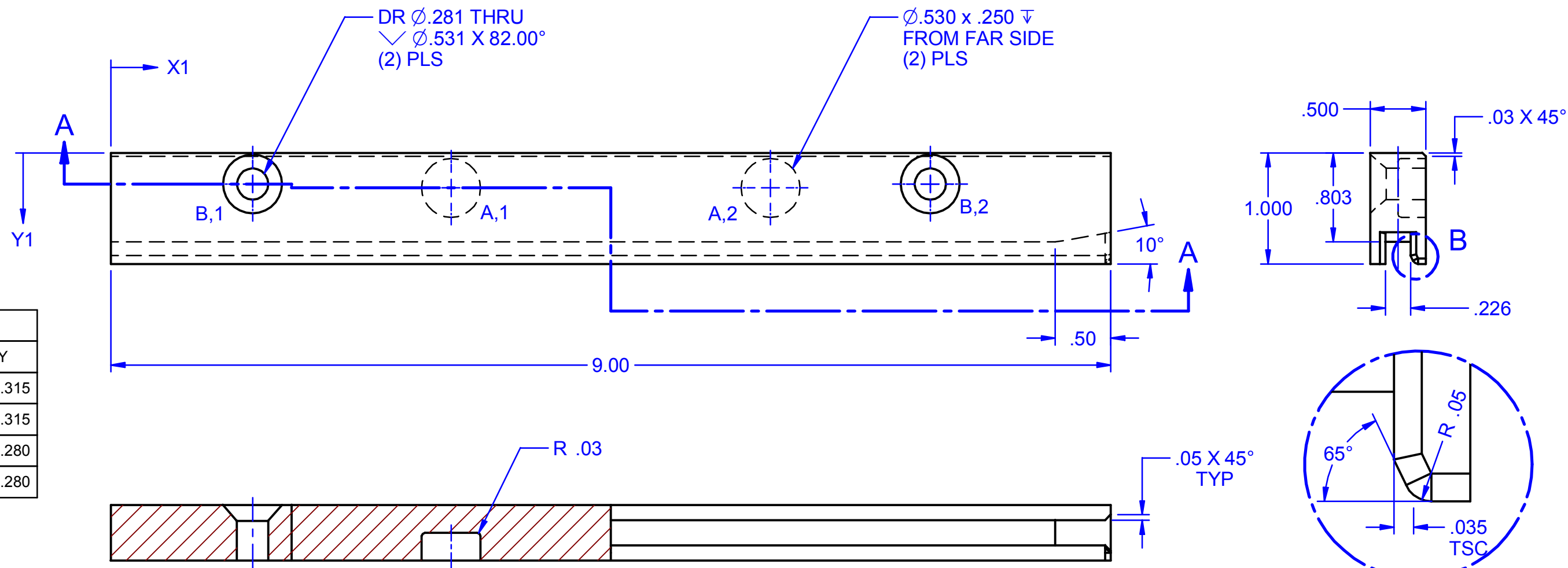

HOLE TABLE		
HOLE	X	Y
A,1	3.063	-.315
A,2	5.938	-.315
B,1	1.275	-.280
B,2	7.375	-.280

SECTION A-A

DETAIL B  
5:1

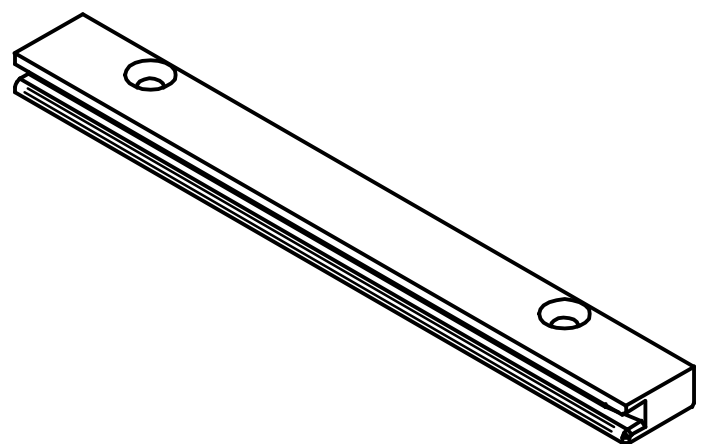

<b>CONTENTS:</b> <b>2637_G10</b> <b>GUIDE RAIL</b> ..		<b>XYZ SIZE -- (X) 9.00 x (Y) 1.00 x (Z) .50</b> <b>MATL -- S-7</b> <b>MASS -- 1.10 LBS   DENSITY = 0.3</b> <b>HT TR -- 52-54Rc</b> <b>ORDER No. --</b> <b>VENDOR --</b>	
DETAILED <b>9/5/2002</b>	LAST SAVE <b>9/5/2002</b>	TOLERANCE UNLESS OTHERWISE SPECIFIED .0 DECIMAL $\pm$ .030 .00 DECIMAL $\pm$ .010 .000 DECIMAL $\pm$ .001 ANGULAR $\pm$ 1/2° SCREWS $\pm$ .010   DOWELS $\pm$ .0005	FILE <b>2637_g10.dft</b> SCALE <b>1 / 1 UNLESS NOTED</b> JOB No. <b>2637</b> DETAILER <b>SRC</b> DESIGNER <b>SRC</b> CHECKER <b>..</b>
SUMMIT TOOL DESIGN WARRANTS THE DRAWING TO BE DIMENSIONALLY CORRECT. CUSTOMER SHALL DETERMINE IF THE DESIGN IS APPROPRIATE FOR THE INTENDED USE.  SUMMIT TOOL DESIGN SHALL BE LIABLE SOLELY FOR DIMENSIONAL ERRORS AND SHALL NOT BE LIABLE FOR INCIDENTAL OR CONSEQUENTIAL DAMAGE.		PROJECT <b>FUEL DOOR HINGE - PROGRESSIVE DIE</b> <b>CUSTOMER P/N 93874-7S200</b>	
			
		TOOL NO. <b>..</b> SHEET <b>1 OF 1</b>	

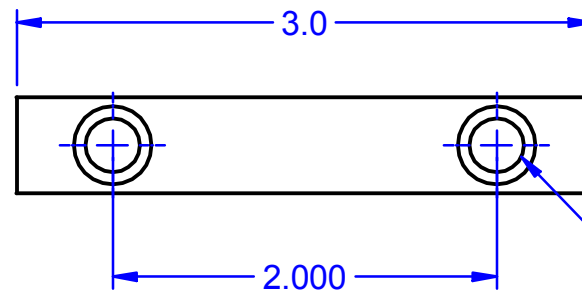

DR Ø.281 THRU  
 □ Ø.406 x .280▽  
 (2) PLS

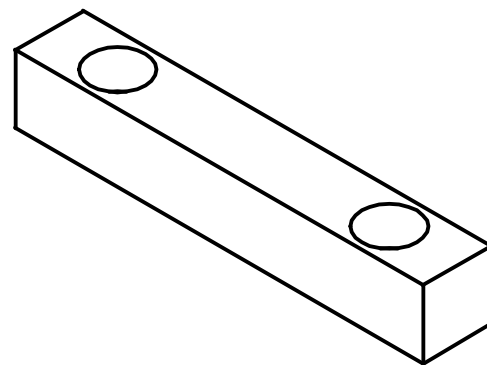
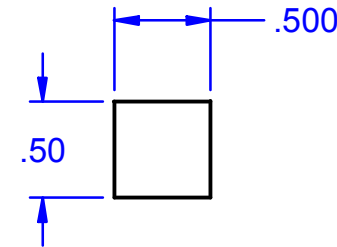

<b>CONTENTS:</b> <b>2637_MISC02</b> <b>KEY</b>  ..		<b>XYZ SIZE -- (X) 3.00 x (Y) .50 x (Z) .50</b> <b>MATL -- A-2</b> <b>MASS -- 0.18 LBS   DENSITY = 0.3</b> <b>HT TR -- 58-60Rc</b> <b>ORDER No. --</b> <b>VENDOR --</b>	
--	--	--	--

DETAILED <b>8/29/2002</b>	LAST SAVE <b>8/29/2002</b>	TOLERANCE UNLESS OTHERWISE SPECIFIED .0 DECIMAL ± .030 .00 DECIMAL ± .010 .000 DECIMAL ± .001 ANGULAR ± 1/2° SCREWS ± .010   DOWELS ± .0005	FILE <b>2637_misc02.dft</b> SCALE <b>1 / 1 UNLESS NOTED</b> JOB No. <b>2637</b> DESIGNER <b>SRC</b>	DETAILER <b>SRC</b> CHECKER <b>..</b>	 <b>SUMMIT TOOL DESIGN</b> TOOL NO. <b>..</b> SHEET <b>1 OF 1</b>
SUMMIT TOOL DESIGN WARRANTS THE DRAWING TO BE DIMENSIONALLY CORRECT. CUSTOMER SHALL DETERMINE IF THE DESIGN IS APPROPRIATE FOR THE INTENDED USE.  SUMMIT TOOL DESIGN SHALL BE LIABLE SOLELY FOR DIMENSIONAL ERRORS AND SHALL NOT BE LIABLE FOR INCIDENTAL OR CONSEQUENTIAL DAMAGE.		PROJECT <b>FUEL DOOR HINGE - PROGRESSIVE DIE</b> <b>CUSTOMER P/N 93874-7S200</b>			



DR  $\varnothing$ .38 x 2.51  $\nabla$   
 $\square$   $\varnothing$ .50 x 2.50  $\nabla$

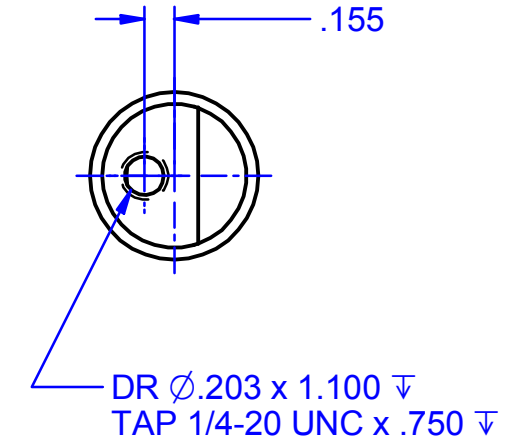
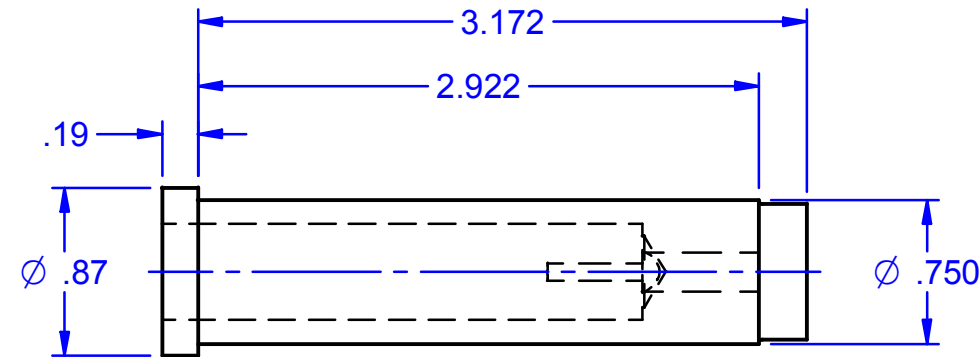
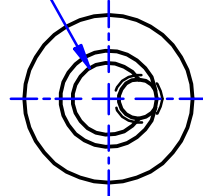

DR  $\varnothing$ .203 x 1.100  $\nabla$   
 TAP 1/4-20 UNC x .750  $\nabla$

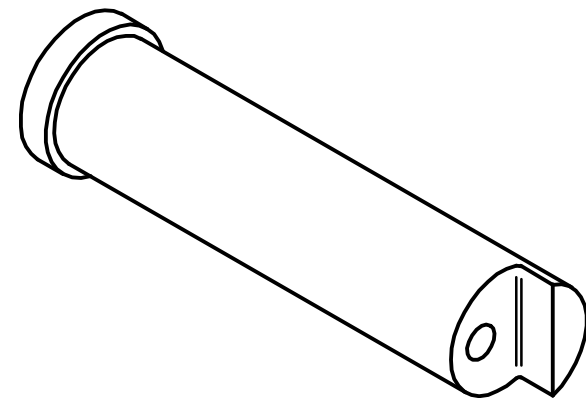
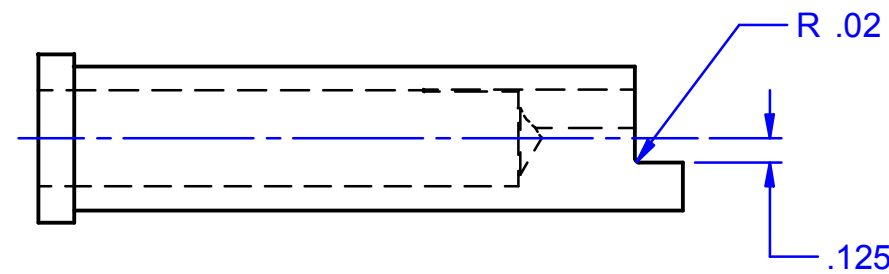

**CONTENTS:**  
**2637\_SP01**  
**RAIL LIFTER**  
 ..

**XYZ SIZE -- (X) DIA x (Y) .87 x (Z) 4.50**  
**MATL -- A-2**  
**MASS -- 0.26 LBS | DENSITY = 0.3**  
**HT TR -- 59-61Rc**  
**ORDER No. --**  
**VENDOR --**

DETAILED **8/28/2002** | LAST SAVE **8/28/2002**

TOLERANCE UNLESS OTHERWISE SPECIFIED  
 .0 DECIMAL  $\pm$  .030  
 .00 DECIMAL  $\pm$  .010  
 .000 DECIMAL  $\pm$  .001  
 ANGULAR  $\pm$  1/2°  
 SCREWS  $\pm$  .010 | DOWELS  $\pm$  .0005

FILE **2637\_sp01.dft**  
 SCALE **1 / 1 UNLESS NOTED**  
 JOB No. **2637** | DETAILER **SRC**  
 DESIGNER **SRC** | CHECKER **..**

SUMMIT TOOL DESIGN WARRANTS THE DRAWING TO BE DIMENSIONALLY CORRECT. CUSTOMER SHALL DETERMINE IF THE DESIGN IS APPROPRIATE FOR THE INTENDED USE.  
 SUMMIT TOOL DESIGN SHALL BE LIABLE SOLELY FOR DIMENSIONAL ERRORS AND SHALL NOT BE LIABLE FOR INCIDENTAL OR CONSEQUENTIAL DAMAGE.

PROJECT **FUEL DOOR HINGE - PROGRESSIVE DIE**  
**CUSTOMER P/N 93874-7S200**



TOOL NO. **..**  
 SHEET **1 OF 1**

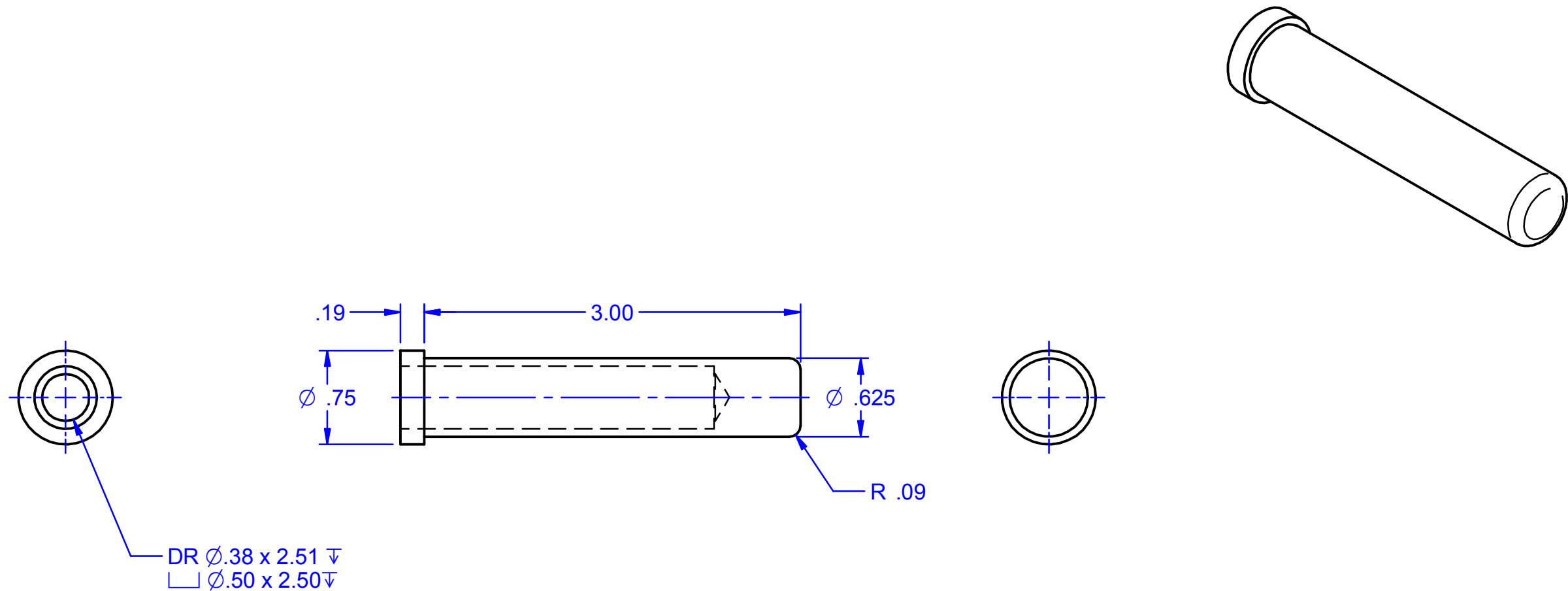

**CONTENTS:**  
**2637\_SP03**  
**LIFTER PIN**  
**..**

**XYZ SIZE -- (X) DIA x (Y) .75 x (Z) 4.50**  
**MATL -- A-2**  
**MASS -- 0.14 LBS | DENSITY = 0.3**  
**HT TR -- 59-61Rc**  
**ORDER No. --**  
**VENDOR --**

DETAILED **8/29/2002** | LAST SAVE **8/29/2002**

TOLERANCE UNLESS OTHERWISE SPECIFIED  
 .0 DECIMAL ± .030  
 .00 DECIMAL ± .010  
 .000 DECIMAL ± .001  
 ANGULAR ± 1/2°  
 SCREWS ± .010 | DOWELS ± .0005

FILE **2637\_sp03.dft**  
 SCALE **1 / 1 UNLESS NOTED**

SUMMIT TOOL DESIGN WARRANTS THE DRAWING TO BE DIMENSIONALLY CORRECT. CUSTOMER SHALL DETERMINE IF THE DESIGN IS APPROPRIATE FOR THE INTENDED USE.

JOB No. **2637** | DESIGNER **SRC**

DETAILER **SRC** | CHECKER **..**

SUMMIT TOOL DESIGN SHALL BE LIABLE SOLELY FOR DIMENSIONAL ERRORS AND SHALL NOT BE LIABLE FOR INCIDENTAL OR CONSEQUENTIAL DAMAGE.

PROJECT **FUEL DOOR HINGE - PROGRESSIVE DIE**  
**CUSTOMER P/N 93874-7S200**



TOOL NO. **..**  
 SHEET **1 OF 1**

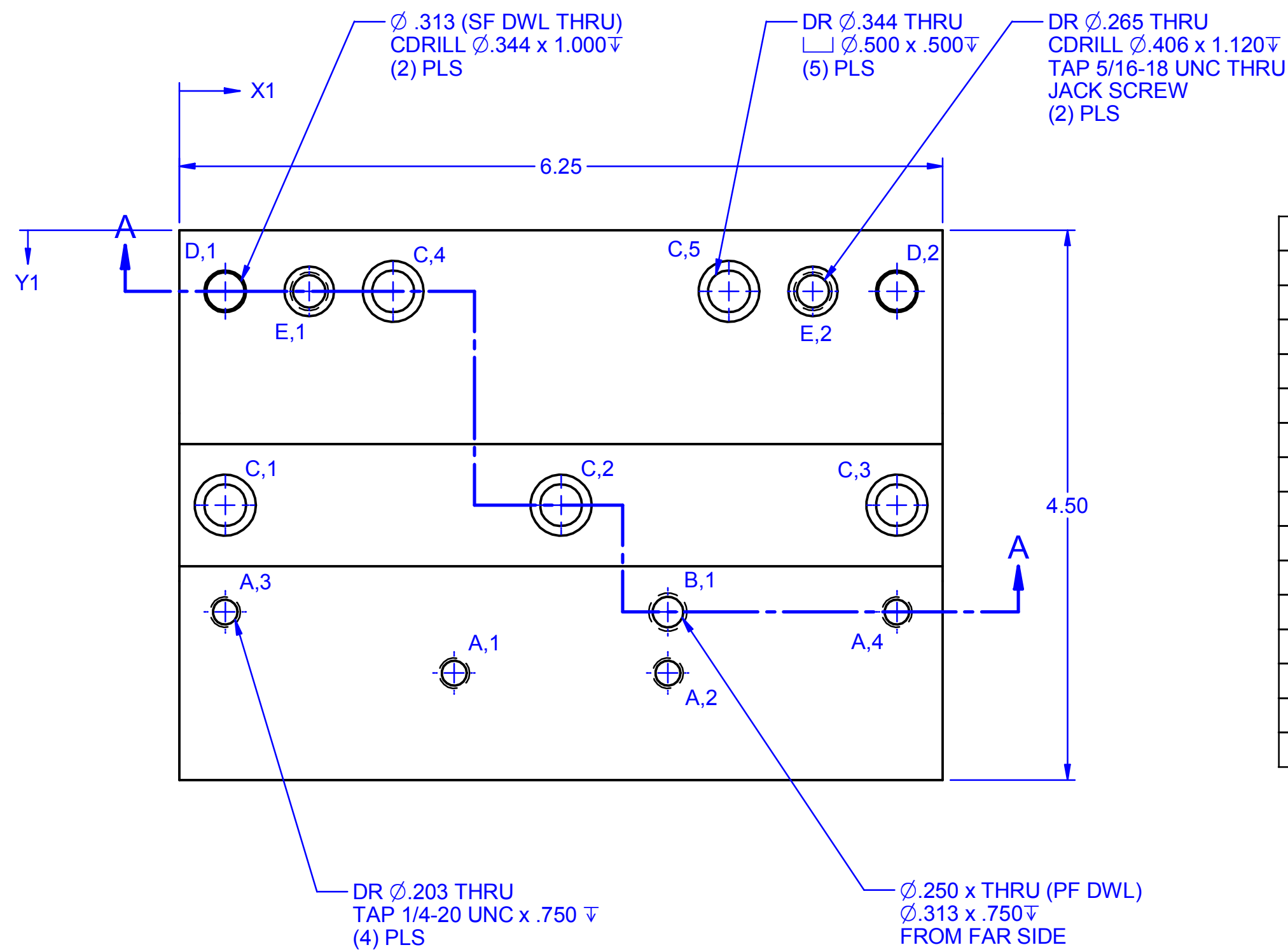

HOLE TABLE		
HOLE	X	Y
A,1	2.250	-3.625
A,2	4.000	-3.625
A,3	.375	-3.125
A,4	5.875	-3.125
B,1	4.000	-3.125
C,1	.375	-2.250
C,2	3.125	-2.250
C,3	5.875	-2.250
C,4	1.750	-.500
C,5	4.500	-.500
D,1	.375	-.500
D,2	5.875	-.500
E,1	1.063	-.500
E,2	5.188	-.500

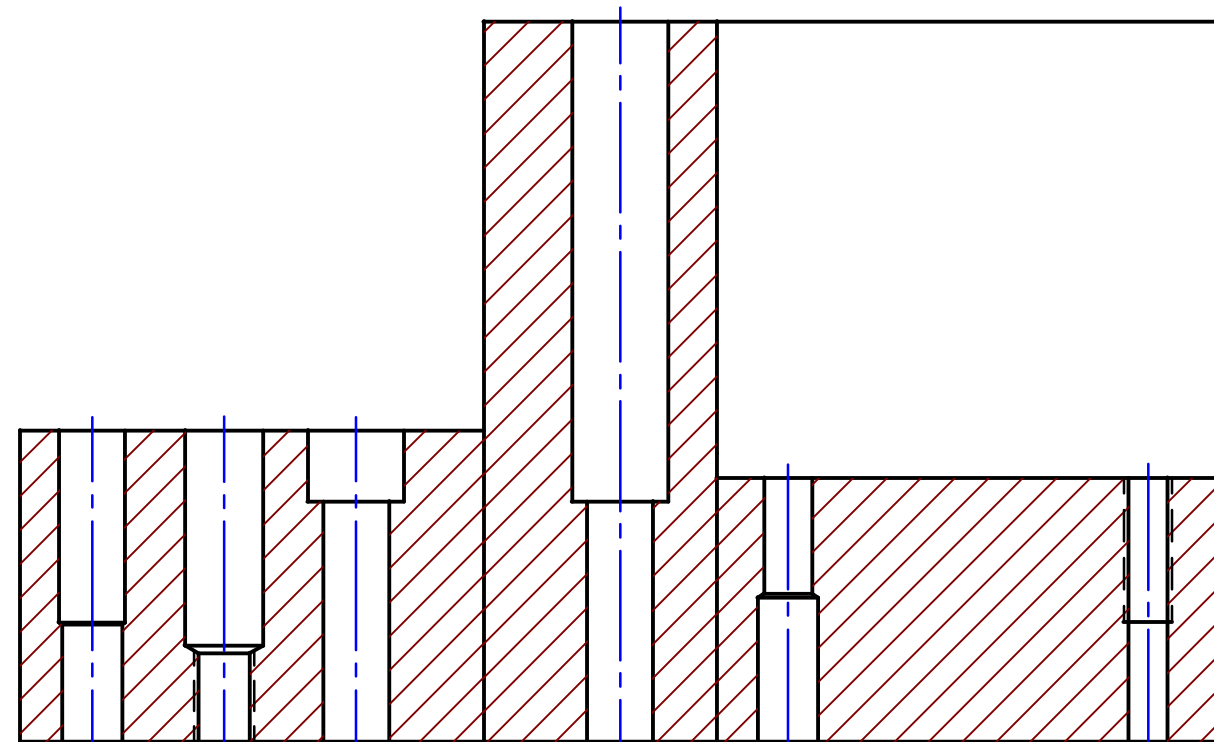
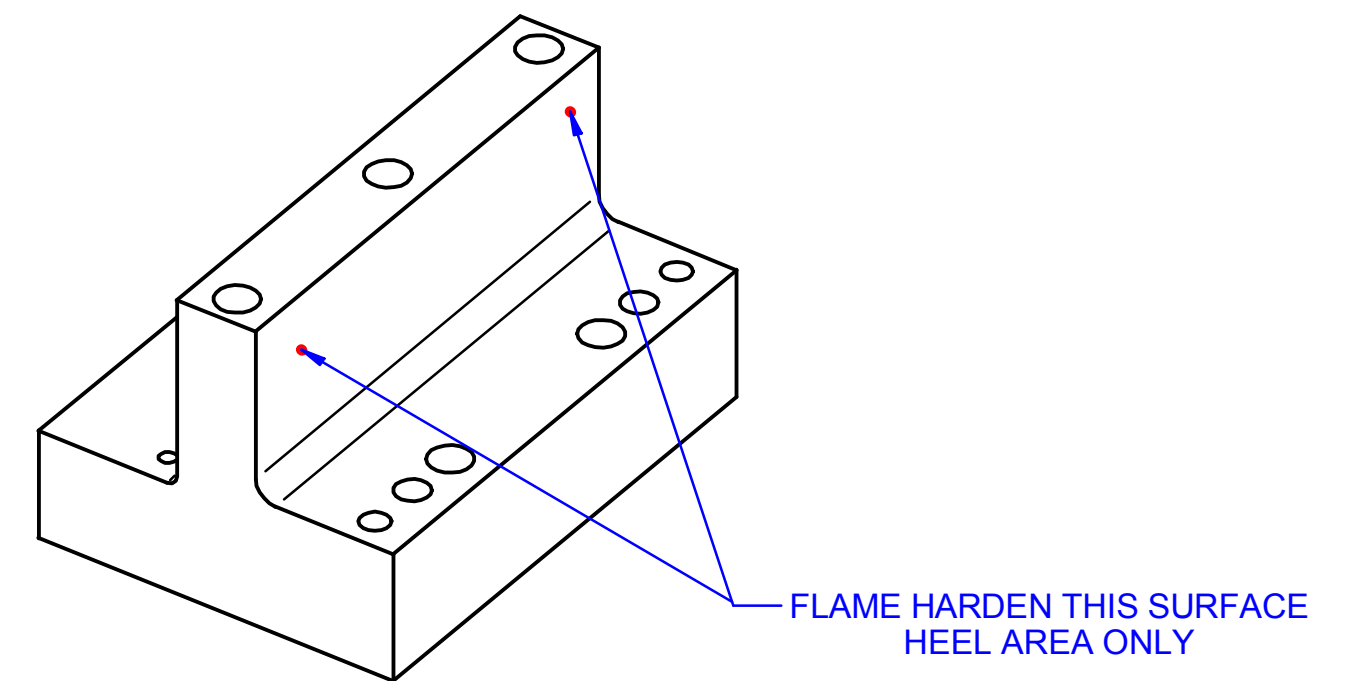
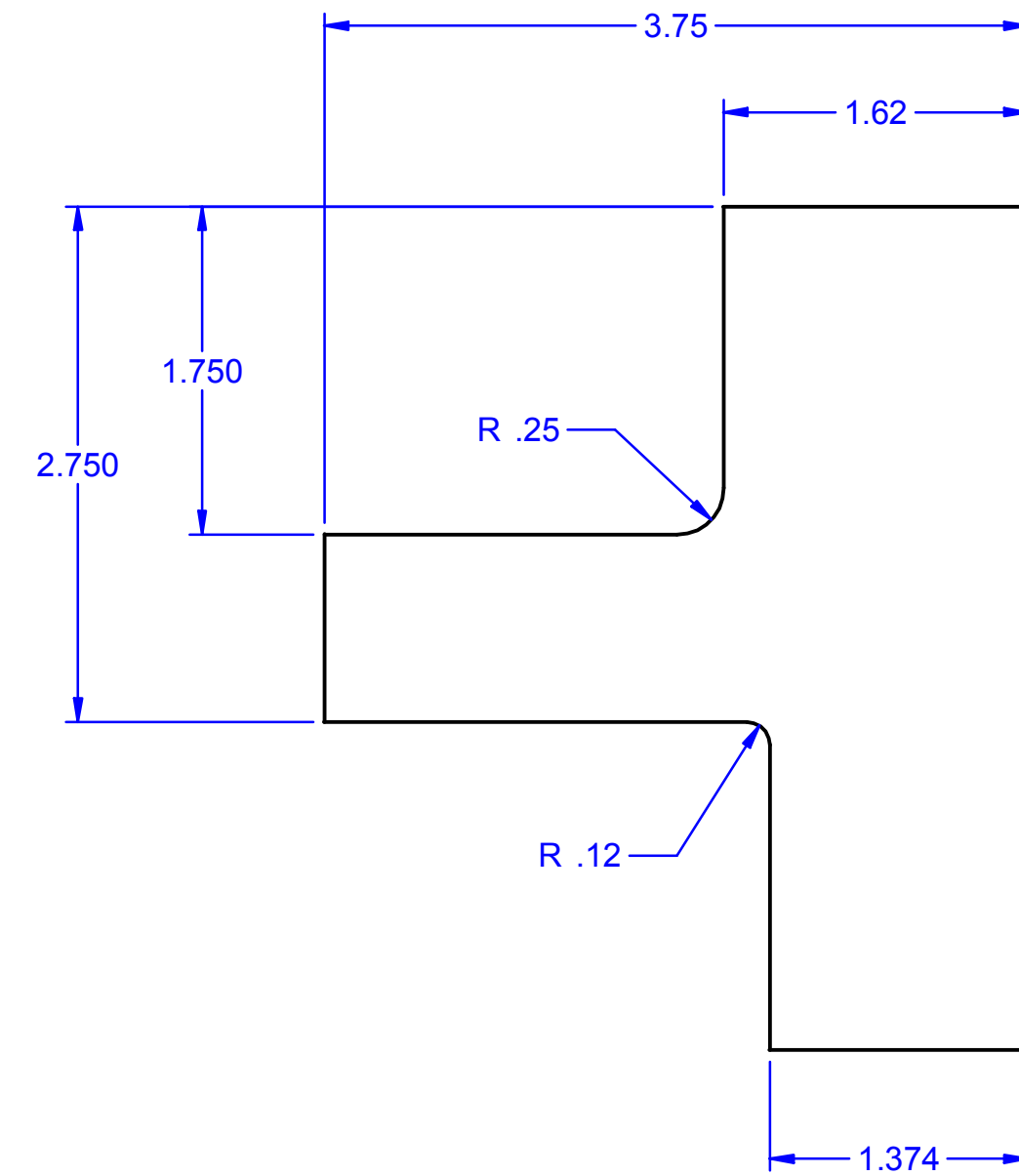

SECTION A-A

**CONTENTS:**  
**2637\_FPU02**  
**PUNCH - FORMING**

XYZ SIZE -- (X) 6.25 x (Y) 4.50 x (Z) 3.75  
 MATL -- 4140  
 MASS -- 15.07 LBS | DENSITY = 0.3  
 HT TR -- FLM-HDN  
 ORDER No. --  
 VENDOR --

DETAILED 9/8/2002 LAST SAVE 9/8/2002

TOLERANCE UNLESS OTHERWISE SPECIFIED  
 .0 DECIMAL ± .030  
 .00 DECIMAL ± .010  
 .000 DECIMAL ± .001  
 ANGULAR ± 1/2'  
 SCREWS ± .010 | DOWELS ± .0005

FILE 2637\_fpu02.dft  
 SCALE 1 / 1 UNLESS NOTED

JOB No. 2637 DESIGNER SRC  
 DETAILER SRC CHECKER ..

SUMMIT TOOL DESIGN WARRANTS THE DRAWING TO BE DIMENSIONALLY CORRECT. CUSTOMER SHALL DETERMINE IF THE DESIGN IS APPROPRIATE FOR THE INTENDED USE.

SUMMIT TOOL DESIGN SHALL BE LIABLE SOLELY FOR DIMENSIONAL ERRORS AND SHALL NOT BE LIABLE FOR INCIDENTAL OR CONSEQUENTIAL DAMAGE.

PROJECT FUEL DOOR HINGE - PROGRESSIVE DIE  
 CUSTOMER P/N 93874-7S200



TOOL NO. ..  
 SHEET 1 OF 1

HOLE	X	Y
A.1	1.625	-7.50
A.2	10.438	-6.750
A.3	23.906	-6.750
A.4	31.500	-6.750
A.5	19.250	-7.50
B.1	.600	-3.350
B.2	7.100	-3.350
B.3	13.600	-3.350
B.4	28.000	-4.025
C.1	5.177	-3.125
C.2	11.677	-3.125
C.3	18.177	-3.125
D.1	31.177	-3.125

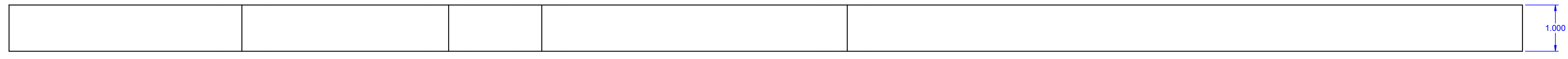
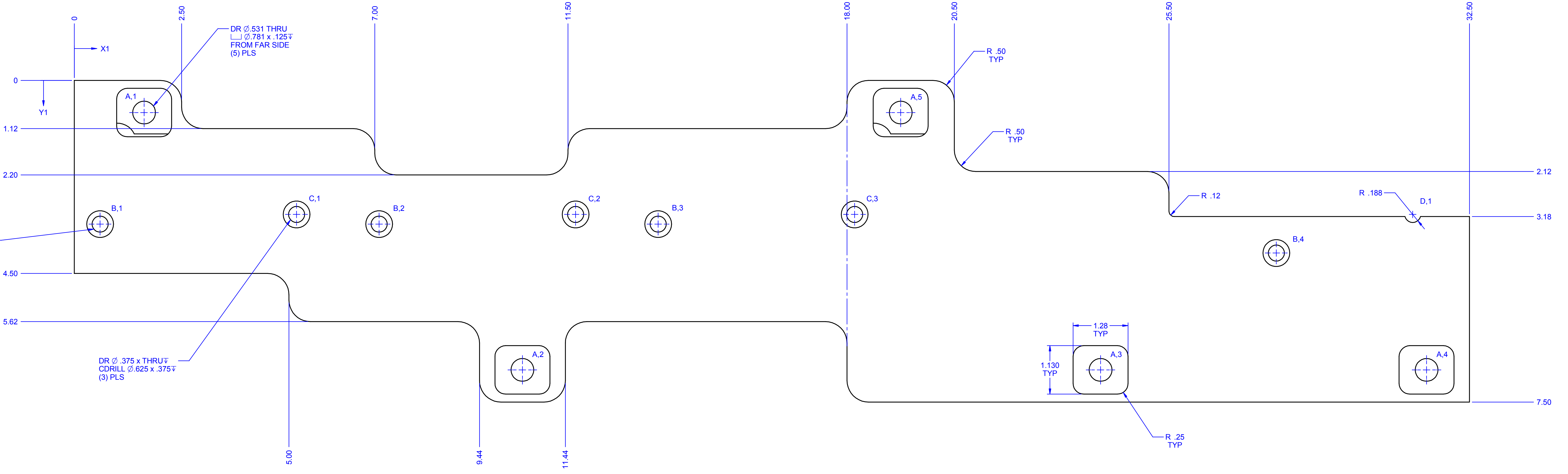

HOLE	X	Y
AA.1	7.125	5.000
AA.2	11.375	5.000
AA.3	20.750	5.000
AA.4	23.750	5.000
AA.5	26.625	5.000
AA.6	31.625	5.000
AA.7	18.625	1.435
AA.8	1.000	1.435
BB.1	8.500	4.788
BB.2	10.011	4.788
CC.1	26.600	3.350

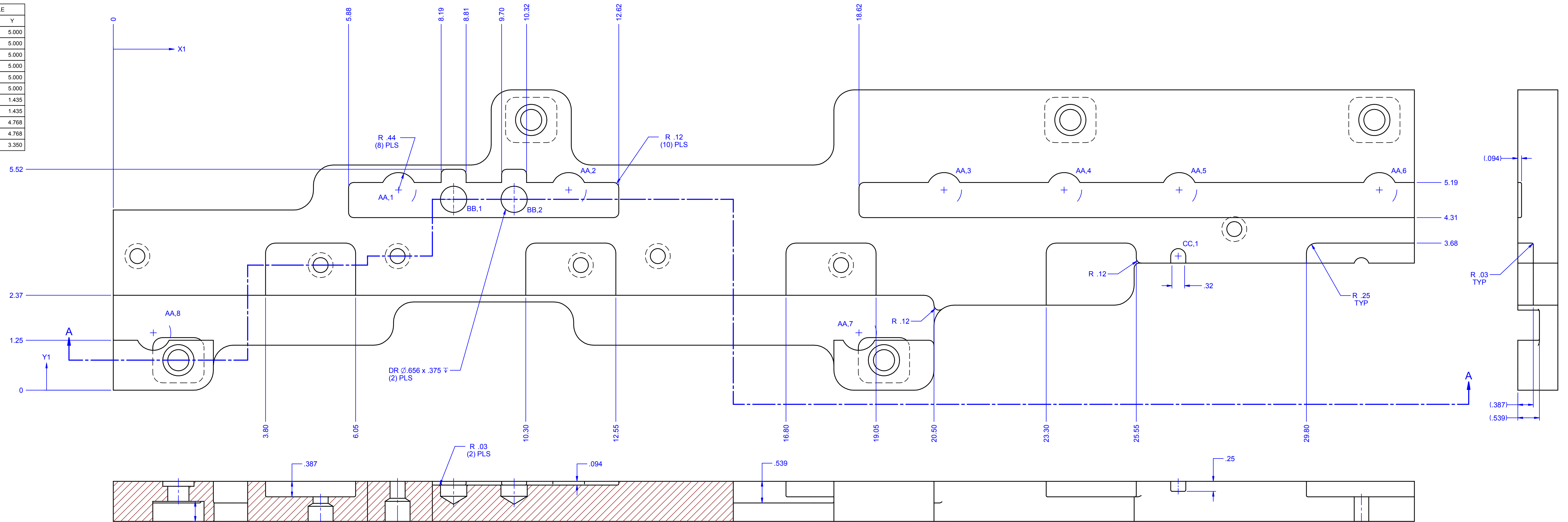

SECTION A-A

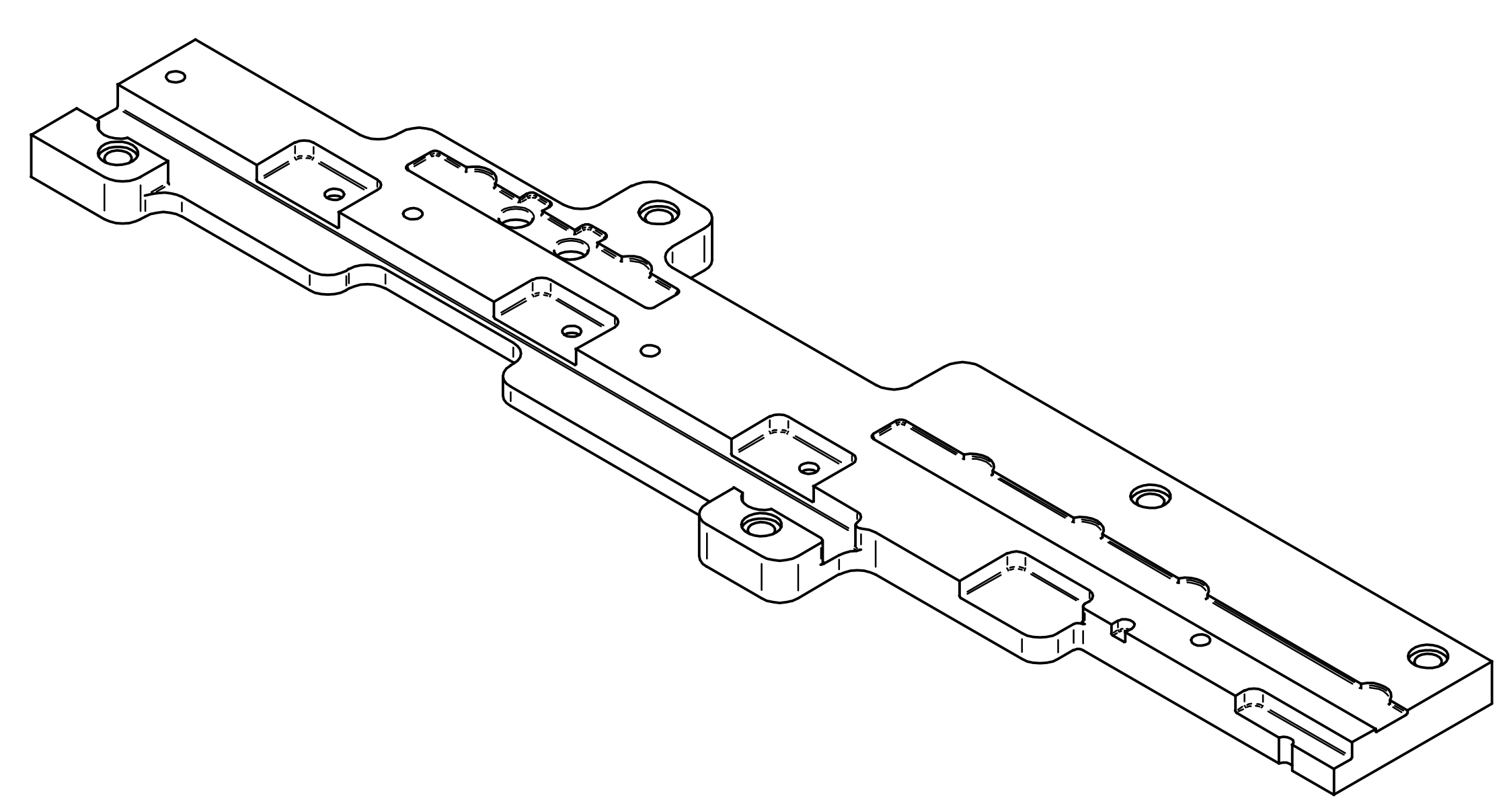
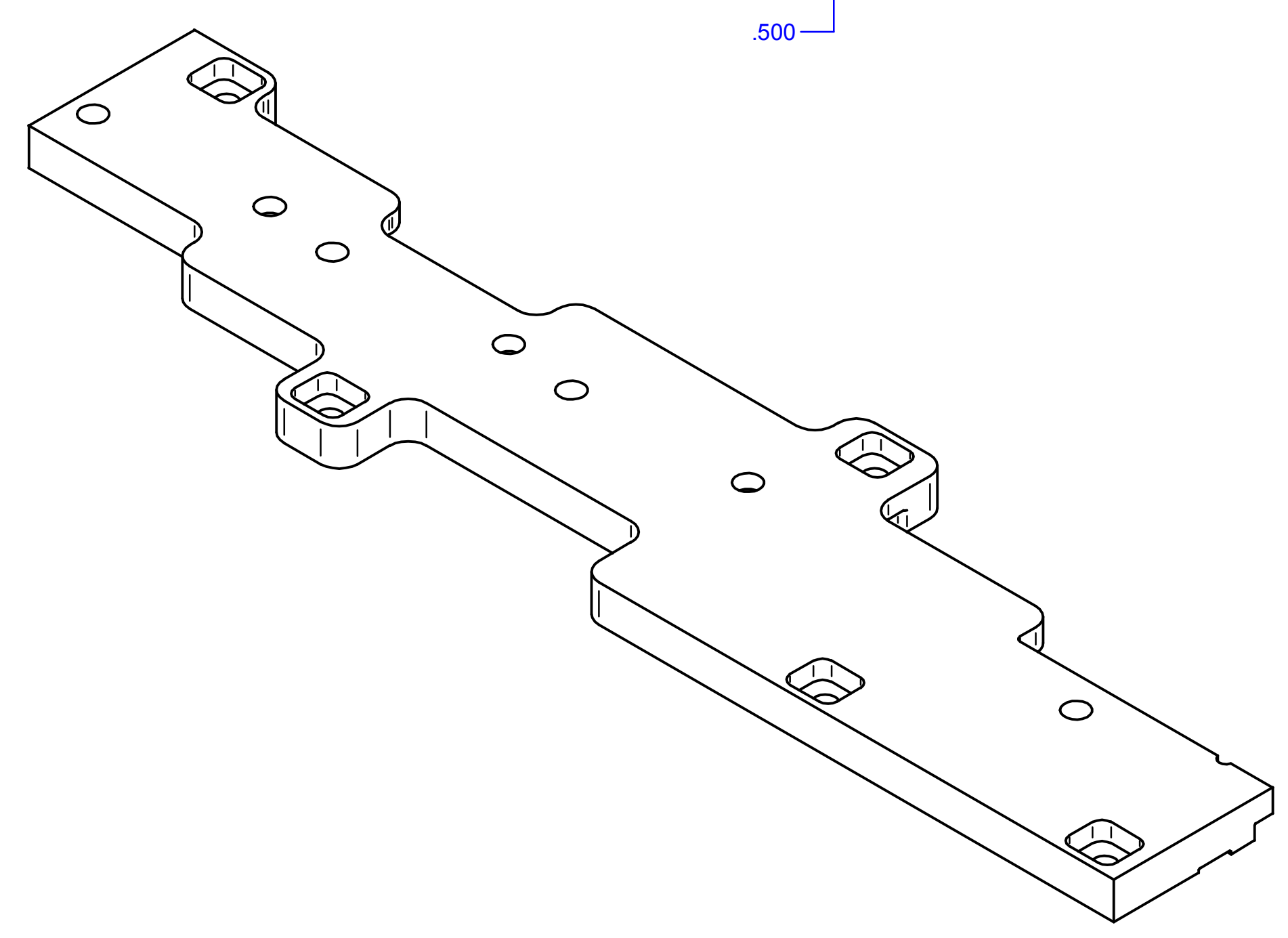

<b>CONTENTS:</b> 2637_STR03 STRIPPER		XYZ SIZE -- (X) 32.50 x (Y) 7.50 x (Z) 1.00 MATL -- 4140 MASS -- 36.68 LBS   DENSITY = 0.3 HT TR -- PRE-HARD ORDER No. -- ORDER AS BURNOUT - SEE DETAIL VENDOR --
DETAILED 9/9/2002	LAST SAVE 9/9/2002	TOLERANCE UNLESS OTHERWISE SPECIFIED 0 DECIMAL = .030 1 DECIMAL = .010 2 DECIMAL = .005 ANGULAR ± .01° SCREWS = 210 DOWELS = .0025
SUMMIT TOOL DESIGN WARRANTS THE DRAWING TO BE DIMENSIONALLY CORRECT. CUSTOMER SHALL DETERMINE IF THE DESIGN IS APPROPRIATE FOR THE INTENDED USE.		FILE 2637_str03.dft SCALE 1/1 UNLESS NOTED JOB No 2637 DESIGNER SRC CHECKER ..
SUMMIT TOOL DESIGN SHALL BE LIABLE SOLELY FOR DIMENSIONAL ERRORS AND SHALL NOT BE LIABLE FOR INCIDENTAL OR CONSEQUENTIAL DAMAGE.		PROJECT FUEL DOOR HINGE - PROGRESSIVE DIE CUSTOMER P/N 93874-7S200
		<b>SUMMIT TOOL DESIGN</b> TOOL NO. .. SHEET 1 OF 1

HOLE	X	Y	HOLE	X	Y
A.1	3.375	-28.125	F.90	33.000	-8.749
A.2	36.500	-28.000	F.91	35.625	-8.749
A.3	67.500	-28.000	F.92	12.883	-8.250
A.4	8.500	2.000	F.93	14.938	-8.250
A.5	36.500	2.000	F.94	18.563	-8.250
A.6	67.500	2.000	F.95	21.438	-8.250
B.1	29.500	-28.125	F.96	24.258	-8.187
B.2	3.500	-28.000	F.97	28.748	-8.187
B.3	13.000	-28.000	F.98	32.375	-7.249
B.4	47.000	-28.000	F.99	33.500	-7.249
B.5	22.000	-25.875	F.100	35.625	-7.249
B.6	4.500	-11.500	F.101	24.258	-7.062
B.7	22.000	1.875	F.102	28.748	-7.062
B.8	13.000	2.000	G.1	21.438	-17.750
B.9	47.000	2.000	G.2	18.863	-17.000
B.10	29.500	2.125	G.3	8.438	-16.500
C.1	3.375	-24.500	G.4	45.100	-16.188
C.2	65.500	-20.500	G.5	46.725	-16.188
C.3	65.500	-3.500	G.6	10.750	-16.750
C.4	8.500	2.000	G.7	16.250	-16.750
C.1	3.375	-24.500	G.8	35.500	-15.625
C.2	65.500	-20.500	G.9	43.350	-15.513
C.3	.000	.000	G.10	5.563	-15.500
C.4	65.500	.000	G.11	49.725	-15.500
E.1	14.250	22.250	G.12	57.500	-15.500
E.2	46.500	22.250	G.13	60.800	-15.500
E.3	9.500	-2.250	G.14	66.625	-15.500
E.4	46.500	-2.250	G.15	2.438	-15.375
F.1	18.563	-18.500	G.16	23.625	-15.000
F.2	21.438	-18.500	G.17	29.375	-15.000
F.3	5.563	-17.250	G.18	4.250	-14.000
F.4	14.438	-17.250	G.19	9.750	-14.000
F.5	-7.313	-17.000	G.20	17.250	-14.000
F.6	-4.868	-17.000	G.21	22.750	-14.000
F.7	18.563	-16.250	G.22	-8.125	-13.014
F.8	21.438	-16.250	G.23	-3.875	-13.014
F.9	48.850	-16.188	G.24	-1.188	-11.625
F.10	11.875	-15.750	G.25	14.888	-10.875
F.11	15.125	-15.750	G.26	21.438	-10.875
F.12	23.625	-15.625	G.27	24.258	-10.807
F.13	29.375	-15.625	G.28	28.748	-10.807
F.14	30.175	-15.625	G.29	4.875	-10.688
F.15	36.425	-15.625	G.30	9.625	-10.688
F.16	44.875	-15.625	G.31	16.400	-10.688
F.17	46.725	-15.625	G.32	22.500	-10.688
F.18	37.500	-15.518	G.33	18.563	-10.000
F.19	44.078	-15.518	G.34	38.350	-10.000
F.20	47.800	-15.500	G.35	48.350	-10.000
F.21	59.350	-15.500	G.36	52.400	-10.000
F.22	61.400	-15.500	G.37	60.800	-10.000
F.23	55.025	-15.500	G.38	66.625	-10.000
F.24	58.650	-15.500	G.39	5.625	-9.938
F.25	59.700	-15.500	G.40	10.375	-9.938
F.26	63.700	-15.500	G.41	17.150	-9.938
F.27	64.750	-15.500	G.42	23.250	-9.938
F.28	67.250	-15.500	G.43	12.883	-8.875
F.29	-3.313	-15.375	G.44	44.875	-9.813
F.30	3.313	-15.375	G.45	46.600	-9.813
F.31	-8.625	-15.250	G.46	24.258	-7.567
F.32	-6.000	-15.250	G.47	28.748	-7.567
F.33	-3.375	-15.250	G.48	31.125	-7.249
F.34	8.500	-15.000	H.1	2.000	-16.500
F.35	9.438	-15.000	H.2	1.500	-16.500
F.36	28.500	-14.625	H.3	38.875	-16.500
F.37	13.500	-14.375	H.4	42.475	-16.500
F.38	33.300	-14.375	H.5	53.825	-16.500
F.39	5.375	-14.000	H.6	57.350	-16.500
F.40	16.750	-13.375	H.7	61.250	-16.500
F.41	18.500	-14.000	H.8	64.750	-16.500
F.42	21.500	-14.000	H.9	-7.000	-15.875
F.43	23.625	-13.625	H.10	-5.000	-15.875
F.44	29.375	-13.625	H.11	32.300	-15.000
F.45	16.750	-13.375	H.12	34.300	-13.000
F.46	16.250	-13.375	H.13	38.875	-9.000
F.47	4.250	-13.125	H.14	42.475	-9.000
F.48	17.250	-13.125	H.15	32.000	-8.749
F.49	30.175	-13.125	H.16	34.000	-8.749
F.50	36.425	-13.125	J.1	46.350	-14.310
F.51	45.750	-13.014	J.2	45.300	-13.000
F.52	-3.250	-13.014	J.3	46.350	-11.990
F.53	-6.000	-12.875	K.1	2.813	-14.000
F.54	9.750	-12.500	K.2	24.500	-13.750
F.55	22.750	-12.500	K.3	31.300	-13.625
F.56	-4.210	-11.783	K.4	35.875	-13.625
F.57	4.750	-11.625	K.5	50.748	-13.425
F.58	-3.250	-11.625	L.1	-250	-13.900
F.59	-3.313	-11.625	L.2	32.250	-13.900
F.60	3.313	-11.625	L.3	38.750	-13.900
F.61	12.063	-11.500	L.4	51.750	-13.900
F.62	14.838	-11.500	L.5	59.750	-13.900
F.63	18.563	-11.500	L.6	64.760	-13.900
F.64	21.438	-11.500	L.7	66.250	-13.900
F.65	24.258	-11.312	L.8	4.850	-13.225
F.66	28.748	-11.312	L.9	11.850	-13.225
F.67	5.625	-10.688	L.10	17.850	-13.225
F.68	16.375	-10.688	L.11	43.850	-13.225
F.69	17.150	-10.688	L.12	16.860	-13.225
F.70	23.250	-10.688	L.13	9.427	-13.900
F.71	44.875	-10.375	L.14	15.927	-13.000
F.72	46.725	-10.375	L.15	22.427	-13.000
F.73	37.500	-10.000	L.16	41.927	-13.000
F.74	44.875	-10.000	M.1	5.250	-11.310
F.75	47.800	-10.000	M.2	10.800	-11.310
F.76	50.300	-10.000	M.3	16.775	-11.310
F.77	51.400	-10.000	M.4	22.875	-11.310
F.78	55.025	-10.000	N.1	24.378	-6.187
F.79	58.650	-10.000	N.2	28.628	-6.187
F.80	59.700	-10.000	N.3	24.378	-4.887
F.81	63.700	-10.000	N.4	28.628	-4.887
F.82	64.750	-10.000	P.1	11.375	-14.875
F.83	67.250	-10.000	P.2	15.625	-14.875
F.84	4.875	-9.938	P.3	25.000	-14.875
F.85	9.625	-9.938	P.4	28.500	-14.875
F.86	16.400	-9.938	P.5	30.875	-14.875
F.87	22.500	-9.938	P.6	35.875	-14.875
F.88	48.850	-10.875	P.7	38.350	-14.875
F.89	30.375	-9.749	P.8	42.913	-14.875



HOLE	X	Y
AA.1	3.375	16.875
AA.2	1.625	14.875
AA.3	1.625	16.875
AA.4	54.025	13.625
AA.5	52.875	15.875
AA.6	56.375	15.875

**CONTENTS:**  
**2637\_DS01**  
**DIE SHOE**  
**700 SERIES ITEM**

DATE: 01/12/2022  
 LAST SAVE: 01/12/2022  
 TOLERANCE UNLESS OTHERWISE SPECIFIED: 0.0005 IN / 0.0127 MM  
 DIMENSIONS ARE IN INCHES UNLESS OTHERWISE NOTED  
 SCALE: 1/2 UNLESS NOTED  
 FILE: 2637\_DS01.DR  
 DRAWING NO: 2637  
 PART NAME: DIE SHOE  
 PROJECT: FUEL DOOR HINGE - PROGRESSIVE DIE  
 CUSTOMER PIN: 93874-73200

XYZ SIZE - (X) 79.00 x (Y) 30.00 x (Z) 3.50  
 MATL - PUR  
 MASS - 2985.25 LBS | DENSITY = 0.3  
 HT TR - N/A  
 ORDER NO. - SEE DETAIL LAYOUT  
 VENDOR - SUPERICK

DRAWING TO BE DIMENSIONALLY CORRECT  
 CUSTOMER SHALL INTERVIEW THE DESIGN CHECKER  
 BLANKET TOOL DESIGNER'S RELEASE  
 SOLELY FOR DIMENSIONAL ERRORS AND SHALL NOT BE LIABLE FOR INCIDENTAL OR CONSEQUENTIAL DAMAGE

**SUMMIT TOOL DESIGN**  
 TOOL NO. 1071  
 SHEET 1 OF 1

HOLE TABLE	HOLE TABLE
HOLE X Y	HOLE X Y
A.1 -21.625 -19.375	E.14 -40.250 -11.242
A.2 -18.375 -19.375	E.15 -41.627 -10.492
A.3 -8.625 -18.125	E.16 -43.250 -10.258
A.4 -5.375 -18.125	E.17 -40.250 -10.258
A.5 -21.625 -17.625	E.18 -41.627 -9.908
A.6 -18.375 -17.625	F.1 -35.750 -16.625
A.7 -8.625 -16.375	F.2 -28.150 -16.625
A.8 -5.375 -16.375	F.3 -14.688 -16.625
A.9 -4.250 -15.646	F.4 -23.000 -10.625
A.10 -6.250 -15.646	F.5 -5.975 -10.625
A.11 -294 -14.789	G.1 -46.750 -16.500
A.12 -2.475 -14.665	G.2 -59.250 -16.500
A.13 -1.125 -14.665	G.3 -51.900 -16.500
A.14 -40.188 -14.650	G.4 -65.750 -9.000
A.15 -59.312 -14.650	G.5 -59.250 -9.000
A.16 -52.188 -14.650	H.1 -43.000 -16.500
A.17 -51.312 -14.650	H.2 -37.850 -16.500
A.18 -38.188 -14.650	H.3 -43.000 -9.000
A.19 -38.313 -14.650	H.4 -38.100 -9.000
A.20 -32.688 -14.650	J.1 -2.025 -16.125
A.21 -31.812 -14.650	J.2 -8.325 -16.125
A.22 -28.488 -14.396	J.3 -3.900 -11.556
A.23 -61.325 -14.396	J.4 -3.200 -11.556
A.24 -5.54 -14.331	K.1 -46.000 -16.000
A.25 -1.875 -14.148	K.2 -48.125 -10.000
A.26 -3.225 -14.040	L.1 -66.619 -14.762
A.27 -44.288 -13.975	L.2 -65.312 -14.650
A.28 -44.212 -13.975	L.3 -64.161 -14.650
A.29 -18.288 -13.975	L.4 -57.412 -13.975
A.30 -17.412 -13.975	L.5 -56.288 -13.975
A.31 -11.788 -13.975	L.6 -47.181 -13.788
A.32 -10.912 -13.975	L.7 -42.489 -12.250
A.33 -5.288 -13.975	L.8 -41.305 -12.250
A.34 -4.412 -13.975	M.1 -46.250 -13.900
A.35 -3.250 -13.896	M.2 -44.750 -13.900
A.36 -5.250 -13.896	M.3 -56.850 -13.225
A.37 -7.250 -13.896	M.4 -41.627 -13.900
A.38 -22.865 -13.750	N.1 -59.750 -13.900
A.39 -21.989 -13.750	N.2 -51.750 -13.900
A.40 -16.389 -13.750	N.3 -38.750 -13.900
A.41 -15.489 -13.750	N.4 -32.250 -13.900
A.42 -9.875 -13.750	N.5 -290 -13.900
A.43 -8.989 -13.750	N.6 -43.850 -13.225
A.44 -62.522 -13.043	N.7 -17.850 -13.225
A.45 -57.413 -11.692	N.8 -11.300 -13.225
A.46 -54.115 -11.692	N.9 -4.850 -13.225
A.47 -3.206 -11.663	N.10 -22.427 -13.000
A.48 -2.332 -11.683	N.11 -15.927 -13.000
A.49 -1.302 -11.683	N.12 -9.427 -13.000
A.50 -2.176 -11.683	O.1 -2.769 -12.431
A.51 -66.250 -11.125	O.2 -1.739 -12.431
A.52 -64.769 -11.125	P.1 -42.312 -12.100
A.53 -56.764 -10.975	P.2 -41.542 -12.100
A.54 -51.925 -10.975	Q.1 -41.627 -13.000
A.55 -65.500 -10.750	R.1 -22.817 -13.910
A.56 -38.750 -10.750	R.2 -22.037 -13.910
A.57 -33.000 -10.750	R.3 -16.317 -13.910
A.58 -39.250 -10.750	R.4 -15.037 -13.910
A.59 -21.625 -10.125	R.5 -9.817 -13.910
A.60 -18.375 -10.125	R.6 -9.037 -13.910
A.61 -15.125 -10.125	S.1 -22.427 -13.000
A.62 -11.875 -10.125	S.2 -15.927 -13.000
A.63 -34.375 -9.000	S.3 -9.427 -13.000
A.64 -31.625 -9.000	T.1 -2.769 -12.431
A.65 -28.628 -8.812	U.1 -3.197 -11.526
A.66 -24.378 -8.812	U.2 -2.381 -11.526
A.67 -21.625 -8.375	V.1 -65.500 -9.000
A.68 -18.375 -8.375	V.2 -65.000 -24.000
A.69 -15.125 -8.375	V.3 -7.500 -24.000
A.70 -11.875 -8.375	V.4 -9.000 -9.000
A.71 -28.628 -7.062	W.1 -43.250 -15.750
A.72 -24.378 -7.062	W.2 -55.915 -15.750
B.1 -21.625 -18.875	W.3 -41.627 -15.900
B.2 -18.375 -18.875	W.4 -53.250 -13.975
B.3 -8.625 -17.625	W.5 -58.500 -13.375
B.4 -5.375 -17.625	W.6 -38.100 -12.750
B.5 -3.250 -15.646	W.7 -43.250 -10.750
B.6 -7.250 -15.646	W.8 -40.250 -10.750
B.7 -3.225 -14.665	W.9 -41.627 -10.000
B.8 -1.875 -14.665	W.1 -33.000 -16.992
B.9 -1.125 -14.148	W.2 -33.000 -16.992
B.10 -2.475 -14.040	W.3 -13.000 -15.242
B.11 -42.458 -13.896	W.4 -35.435 -14.492
B.12 -40.886 -13.896	W.5 -30.665 -14.492
B.13 -57.413 -10.875	W.6 -13.000 -14.258
B.14 -52.423 -10.875	W.7 -35.435 -13.908
B.15 -37.750 -9.000	W.8 -30.665 -13.908
B.16 -30.250 -9.000	W.9 -25.500 -13.492
B.17 -21.625 -9.000	W.10 -20.000 -13.492
B.18 -18.375 -9.000	W.11 -5.875 -12.967
B.19 -15.125 -9.000	W.12 -28.000 -12.908
B.20 -11.875 -9.000	W.13 -20.000 -12.908
B.21 -28.688 -7.687	W.14 -5.875 -11.883
B.22 -24.378 -7.687	X.1 -48.125 -16.492
C.1 -48.500 -18.440	X.2 -48.125 -15.908
C.2 -45.500 -17.850	X.3 -46.000 -10.492
C.3 -48.500 -8.150	X.4 -46.000 -9.908
C.4 -45.500 -7.560	Y.1 -1.750 -16.492
D.1 -48.500 -18.440	Y.2 -1.750 -15.908
D.2 -48.000 -17.850	Y.3 -1.250 -13.742
D.3 -46.000 -8.150	Y.4 -1.250 -12.758
D.4 -48.000 -7.560	Y.5 -4.000 -12.742
E.1 -63.250 -16.242	Y.6 -4.000 -11.758
E.2 -59.915 -16.242	Z.1 -33.000 -16.500
E.3 -41.927 -15.962	Z.2 -13.000 -14.750
E.4 -63.250 -15.258	Z.3 -35.435 -14.000
E.5 -59.915 -15.258	Z.4 -30.665 -14.000
E.6 -41.927 -15.008	Z.5 -26.500 -13.900
E.7 -53.250 -14.367	Z.6 -20.000 -13.900
E.8 -58.500 -13.967	Z.7 -5.975 -12.375
E.9 -63.250 -13.383	AA.1 -48.125 -16.000
E.10 -38.100 -13.242	AA.2 -46.000 -10.000
E.11 -58.580 -12.883	AA.1 -1.750 -16.600
E.12 -38.100 -12.258	AA.2 -1.250 -13.250
E.13 -43.250 -11.242	AA.3 -4.000 -12.250

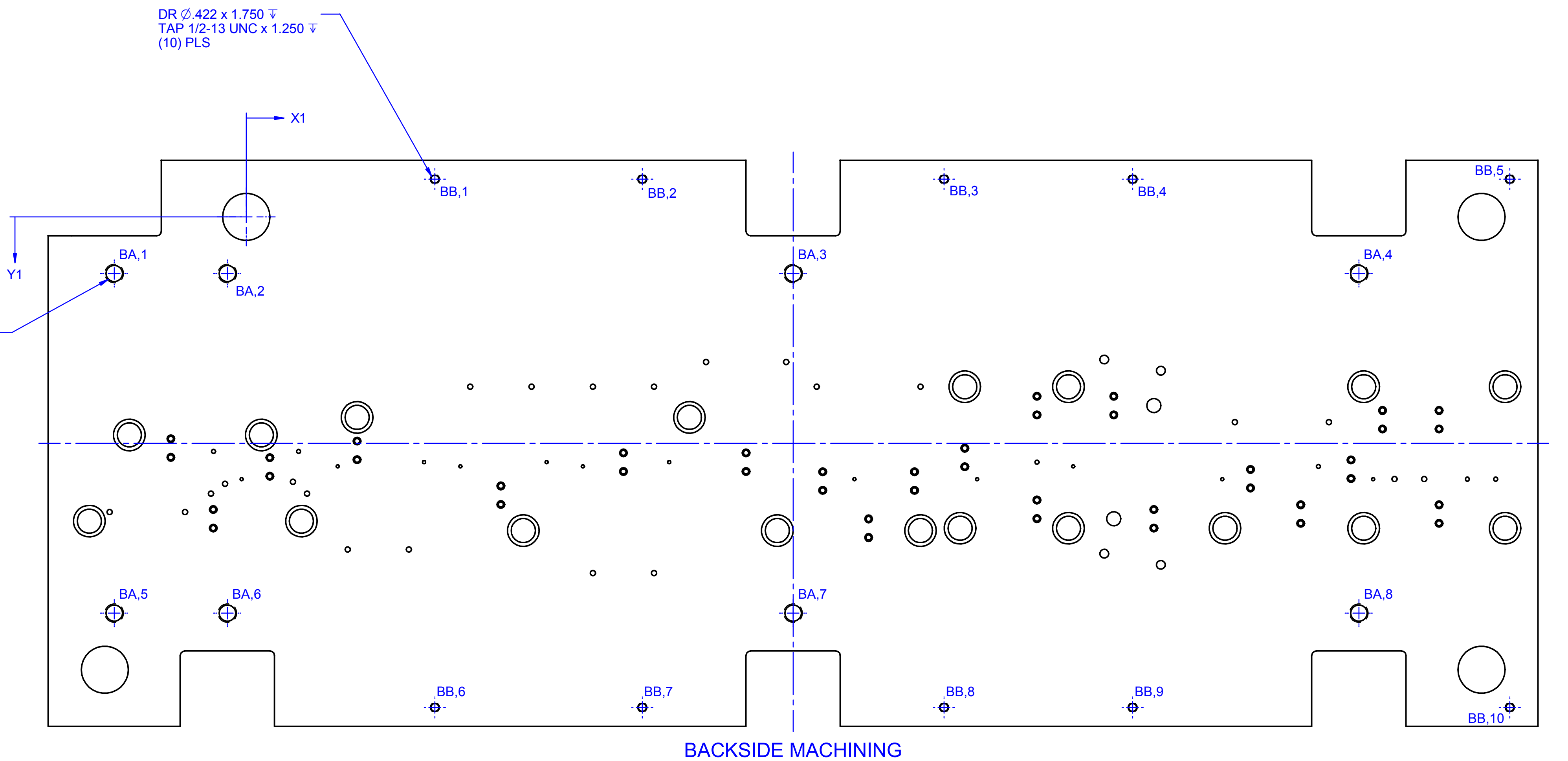
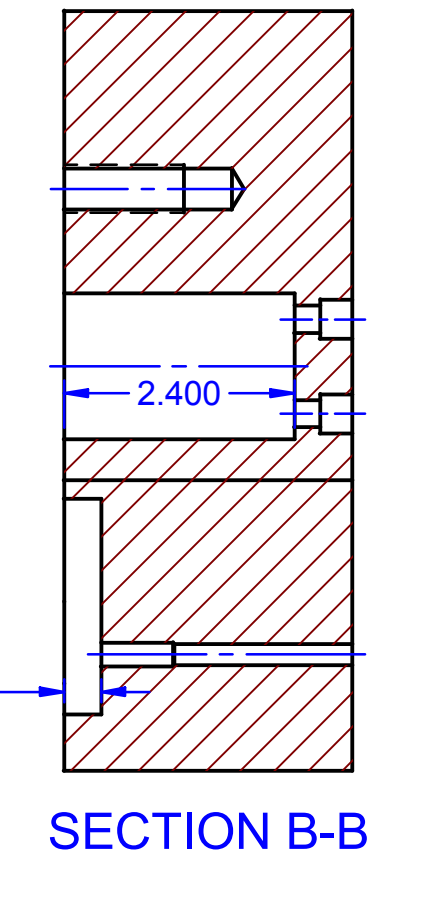
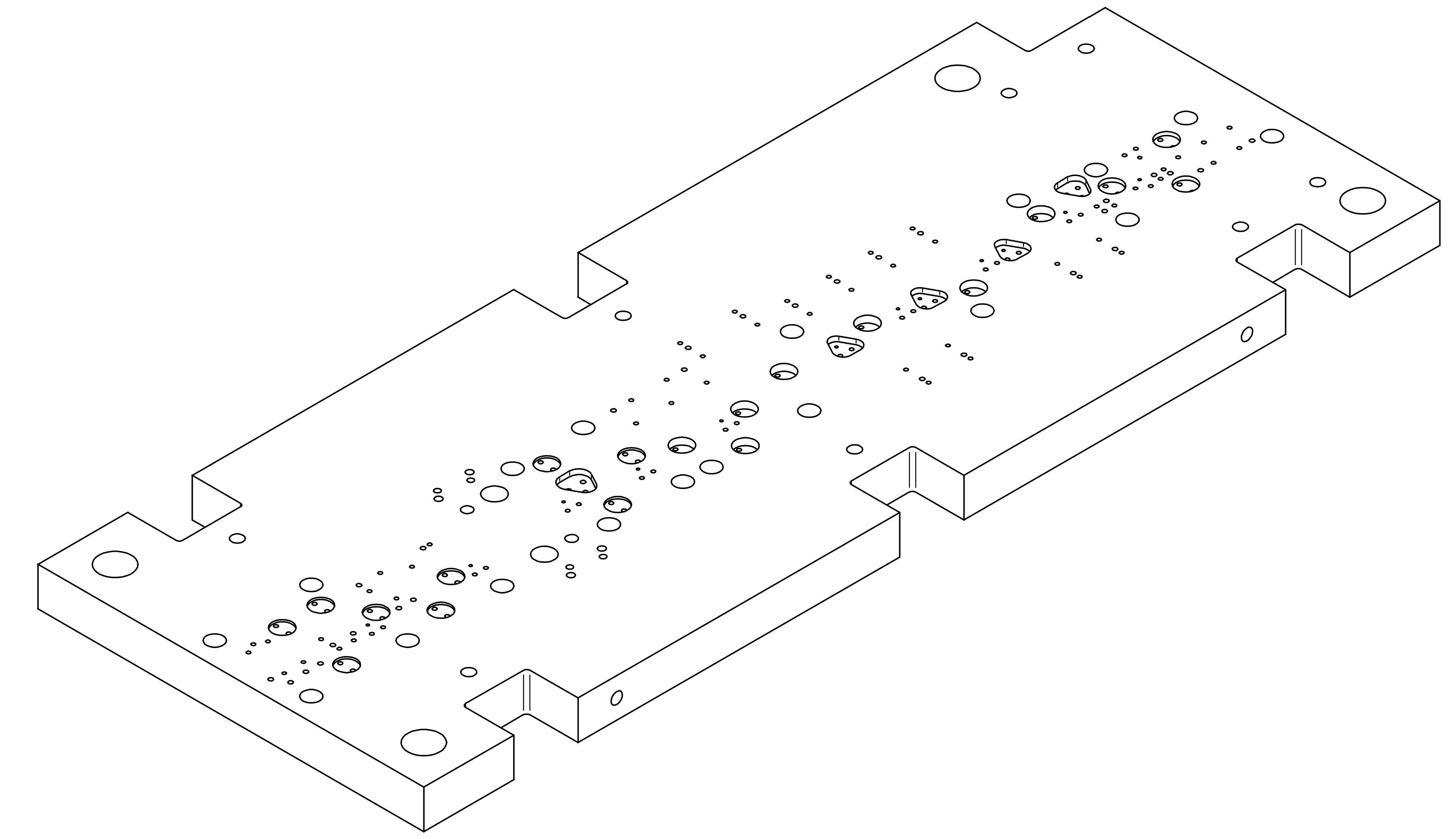
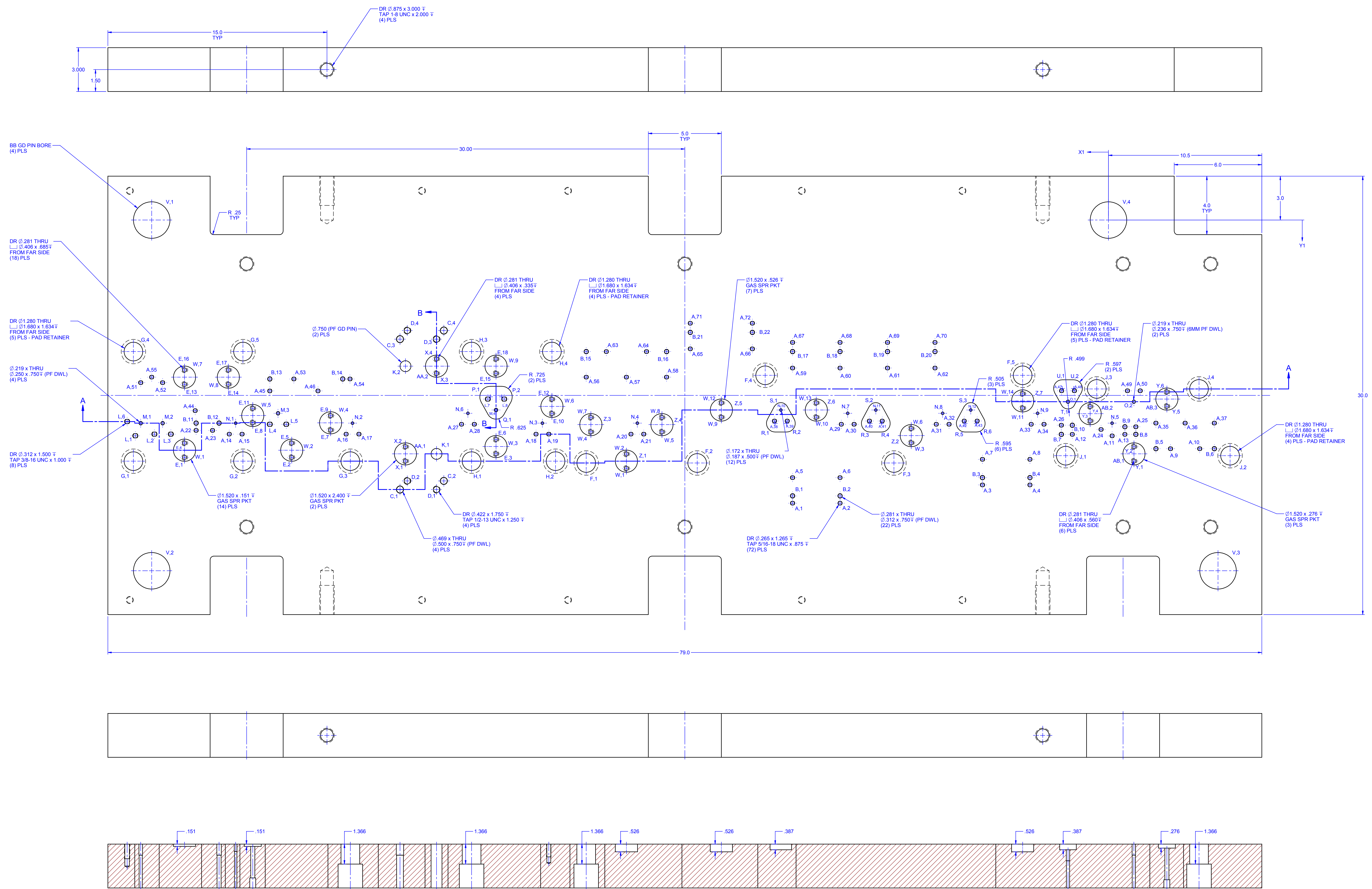

HOLE TABLE	HOLE TABLE
HOLE X Y	HOLE X Y
BA.1 -7.000 -3.000	BB.2 -21.000 -2.000
BA.2 -11.000 -3.000	BB.3 -37.000 -2.000
BA.3 -29.000 -3.000	BB.4 -47.000 -2.000
BA.4 -59.000 -3.000	BB.5 -67.000 -2.000
BA.5 -7.000 -21.000	BB.6 -10.000 -26.000
BA.6 -11.000 -21.000	BB.7 -21.000 -26.000
BA.7 -29.000 -21.000	BB.8 -37.000 -26.000
BA.8 -59.000 -21.000	BB.9 -47.000 -26.000
BB.1 -10.000 -2.000	BB.10 -67.000 -26.000

**CONTENTS:**  
**2637\_DS02**  
**PUNCH HOLDER**  
**800 SERIES ITEM**

KTZ SIZE - (X) 79.00 x (Y) 30.00 x (Z) 3.00  
MATERIAL - PUR  
MASS - 1843.50 LBS | DENSITY = 0.3  
HT TR - N/A  
ORDER NO. - SEE DETAIL LAYOUT  
VENDOR - SUPERIOR

DETAILED 01/22/2002 LAST SAVE 01/22/2002  
SCALE 1/2 UNLESS NOTED  
FILE 2637\_ds02.drt  
SUMMIT TOOL DESIGN INC. 2637  
DESIGNER SRC CHECKER SRC  
PROJECT FUEL DOOR HINGE - PROGRESSIVE DRC  
CUSTOMER PIN 93874-7S20

**SUMMIT TOOL DESIGN**  
SHEET 1 OF 1

PARTS LIST FOR JOB No. 2208 - PROGRESSIVE DIE									BLANKING DIE ASSEMBLY	
LINE ITEM	QTY	DWG No.	DESCRIPTION	X SIZE	Y SIZE	Z SIZE	MATL	HT TR	ORDER No.	VENDOR
101	14		FHSS - 1/4-20 x 5/8				FASTENER			
102*	2		DOWEL PIN - 3/16 DIA x 7/8				FASTENER			
103	4		DOWEL PIN - 5/16 DIA x 1-1/2				FASTENER			
104	4		FHSS - 10-32 x 1/2				FASTENER			
105	11		SHCS - 1/4-20 x 1-1/2				FASTENER			
106	3		SHCS - 1/4-20 x 3/4				FASTENER			
107	3		DIE BUSHING				M-2	PUR	VAX 62-100 P.332	DAYTON
108	10		DOWEL PIN - 5/16 DIA x 1-1/4				FASTENER			
109	28		SHCS - 5/16-18 x 1-1/4				FASTENER			
110	10		DIE SPRING				PUR		DIA 1/2 x 5-1/2 MED DUTY (CUT FROM 12" SPRING)	DANLY
111	2		PROXIMITY SENSOR (12MM)				PUR		BI 2-G12K-AN6X	TURCK
112	3		GAS SPRING				PUR		C180 x 15 GREEN	DADCO
113	2		DIE SPRING				PUR		9-1622-11 (1" x 5-1/2" MED DUTY)	DANLY
114	1	2637_BU01	BACKUP PLATE	2.50	7.13	0.50	A-6	54-56Rc		
115	1	2637_DB01	DIE BLOCK - BLANKING	3.50	6.50	1.50	D-2	59-61Rc		
116	1	2637_DB03	DIE BLOCK - BLANKING	5.00	6.50	1.50	A-2	59-61Rc		
117	1	2637_DB04	DIE BLOCK - BLANKING	8.25	6.50	1.50	A-2	59-61Rc		
118	1	2637_DB05	DIE BLOCK	7.75	6.50	1.50	A-2	59-61Rc		
119	1	2637_FD14	FORM DIE INSERT	2.00	1.63	1.14	D-2	59-61Rc		
120	1	2637_FDB01	DIE BLOCK - FORMING	3.50	6.50	1.50	A-2	59-61Rc		
121	1	2637_G01	GUIDE RAIL	10.25	0.75	0.25	S-7	52-54Rc		
122	1	2637_G02	GUIDE RAIL	10.25	0.75	0.25	S-7	52-54Rc		
123	1	2637_G03	STOCK SHELF	2.50	4.53	0.37	CRS	N/A		

PARTS LIST FOR JOB No. 2208 - PROGRESSIVE DIE									BLANKING DIE ASSEMBLY	
LINE ITEM	QTY	DWG No.	DESCRIPTION	X SIZE	Y SIZE	Z SIZE	MATL	HT TR	ORDER No.	VENDOR
124	1	2637_G04	GUIDE RAIL	8.25	0.75	0.25	S-7	52-54Rc		
125	1	2637_G05	FEED STOP	2.00	0.62	1.62	A-2	59-61Rc		
126	2	2637_G06	GUIDE RAIL	7.77	0.75	0.25	S-7	52-54Rc		
127	1	2637_G07	NEST GAGE	2.25	0.66	0.19	A-2	59-61Rc		
128	1	2637_G08	NEST GAGE	0.79	1.62	0.19	A-2	59-61Rc		
129	5	2637_MISC04	BALANCER	4.50	0.75	1.06	CRS	N/A		
130	1	2637_PD01	PRESSURE PAD	2.50	4.50	1.00	S-7	56-58Rc		
131	2	2637_PD02	KEEPER	2.50	1.50	1.00	A-2	54-56Rc		
132	2	2637_SEN01	SENSOR HOLDER (12MM)	DIA	1.00	4.50	A-2	59-61Rc		
133	2	2637_SEN03	WIRE GUARD	DIA	1.00	4.00	NYLON	N/A		
134	10	2637_SP01	RAIL LIFTER	DIA	0.87	4.50	A-2	59-61Rc		



PARTS LIST FOR JOB No. 2208 - PROGRESSIVE DIE									BLANKING PUNCH ASSEMBLY	
LINE ITEM	QTY	DWG No.	DESCRIPTION	X SIZE	Y SIZE	Z SIZE	MATL	HT TR	ORDER No.	VENDOR
201	4		SHCS - 1/2-13 x 2				FASTENER			
202	7		SHCS - 1/4-20 x 7/8				FASTENER			
203	4		DOWEL PIN - 5/16 DIA x 1-1/4				FASTENER			
204	4		DOWEL PIN - 1/2 DIA x 1-1/4				FASTENER			
205	5		FHSS - 10-32 x 5/8				FASTENER			
206	9		SHCS - 1/2-13 x 1-1/2				FASTENER			
207	2		GUIDE BUSHING - SELF LUBE				PUR		S750-11G	IEM
208	7		SHCS - 5/16-18 x 1-3/4				FASTENER			
209	4		BALL LOCK RETAINER - HRT 37				PUR	PUR	HRT 37	DAYTON
210	3		FHSS - 5/16-18 x 1-3/4				FASTENER			
211	4		BALL LOCK RETAINER - HRT 50				PUR	PUR	HRT 50	DAYTON
212	4		PUNCH - PILOT				M-2	PUR	HPA 37-D350 P.315	DAYTON
213	4		PUNCH - PIERCE				M-2	PUR	HJX 50-C275 P.319	DAYTON
214	2		KEEPER BLOCK	4.00	1.94	2.44	PUR	FLM-HDN	14K32G	IEM
215	1	2637_FPU01	EMBOSS PUNCH	3.00	3.00	2.88	D-2	59-61Rc		
216	1	2637_PD04	UPPER FORM PAD	4.25	8.50	2.88	4140	PRE-HARD		
217	1	2637_PD05	UPPER PAD - FORM INSERT	2.63	2.62	1.25	D-2	59-61Rc		
218	1	2637_PU03	PUNCH - BLANKING	4.00	3.25	3.00	A-2	59-61Rc		
219	1	2637_PU04	PUNCH - BLANKING	7.75	3.50	3.25	A-2	59-61Rc		
220	1	2637_PU05	PUNCH - BLANKING	2.00	2.00	3.00	A-2	59-61Rc		
221	1	2637_SINS01	STRIPPER WINDOW	10.88	3.13	0.25	4140	PRE-HARD		
222	1	2637_STR01	STRIPPER	16.85	9.00	0.63	4140	PRE-HARD		
223	1	2637_STR02	STRIPPER	7.75	9.00	0.63	4140	PRE-HARD		

PARTS LIST FOR JOB No. 2208 - PROGRESSIVE DIE									FORM DIE ASSEMBLY	
LINE ITEM	QTY	DWG No.	DESCRIPTION	X SIZE	Y SIZE	Z SIZE	MATL	HT TR	ORDER No.	VENDOR
301	4		SHCS - 1/4-20 x 2				FASTENER			
302	5		SHCS - 1/4-20 x 1-1/4				FASTENER			
303	4		DOWEL PIN - 5/16 DIA x 1-1/2				FASTENER			
304	6		FHSS - 1/4-20 x 5/8				FASTENER			
305	4		SHSS - 1/2 x 3-3/4				FASTENER			
306	15		SHCS - 5/16-18 x 5/8				FASTENER			
307*	11		FHSS - 10-32 x 1/2				FASTENER			
308*	4		DOWEL PIN - 3/16 DIA x 3/4				FASTENER			
309	1		SHSS - 1/2 x 3-1/2				FASTENER			
310	4		SHCS - 3/8-16 x 2-1/2				FASTENER			
311	6		SHCS - 5/16-18 x 1-1/2				FASTENER			
312*	3		SHCS - 10-32 x 1/2				FASTENER			
313	4		FHSS - 1/4-20 x 1				FASTENER			
314*	8		SHCS - 10-32 x 3/4				FASTENER			
315*	4		SHCS - 1/4-20 x 5/8				FASTENER			
316	8		SHCS - 5/16-18 x 1				FASTENER			
317	8		SHCS - 10-32 x 1				FASTENER			
318	8		SHCS - 1/4-20 x 3/4				FASTENER			
319	40		SHCS - 5/16-18 x 1-1/4				FASTENER			
320	16		SHCS - 5/16-18 x 2-1/2				FASTENER			
321	2		SHSS - 5/16 x 3/8				FASTENER			
322*	4		DOWEL PIN - 3/16 DIA x 5/8				FASTENER			
323	26		DOWEL PIN - 5/16 DIA x 1-1/4				FASTENER			

PARTS LIST FOR JOB No. 2208 - PROGRESSIVE DIE									FORM DIE ASSEMBLY	
LINE ITEM	QTY	DWG No.	DESCRIPTION	X SIZE	Y SIZE	Z SIZE	MATL	HT TR	ORDER No.	VENDOR
324	5		PROXIMITY SENSOR - 5MM				PUR		Bi 1-EG05-AN6X	TURCK
325	2		L-GIB				PUR	PUR	4GAL40GS	IEM
326	2		GAS SPRING				PUR		C90 x 15 YELLOW	DADCO
327	4		SENSOR LOCK NUT - M5				PUR			
328	5		GREASE FITTING - 1/4-28 TAPER				PUR			
329	14		DIE SPRING				PUR		DIA 1/2 x 5-1/2 MED DUTY (CUT FROM 12" SPRING)	DANLY
330	5		SPRING GUARD				PUR		10-24G	IEM
331	10		HEAVY DUTY WASHER				FASTENER		31905	JERGENS
332	5		DIE SPRING				PUR		9-1610-21 (1 x 2-1/2 M. DUTY)	DANLY
333	1	2637_CC01	SLIDE YOKE	3.50	4.00	1.63	A-2	59-61Rc		
334	1	2637_CC02	SLIDE	2.25	3.75	1.13	A-2	59-61Rc		
335	1	2637_CC03	SUPPORT INSERT	2.23	0.24	0.61	D-2	59-61Rc		
336	1	2637_DB06	DIE BLOCK	6.50	2.75	1.50	A-2	58-60Rc		
337	1	2637_DB08	DIE BLOCK - TRIM INSERT	1.00	1.75	1.12	M-2	60-62Rc		
338	1	2637_DB09	DIE BLOCK - TRIM INSERT	1.00	1.75	1.12	M-2	60-62Rc		
339	1	2637_DB10	DIE BLOCK	6.25	3.50	1.50	A-2	59-61Rc		
340	1	2637_DB11	TRIM BLADE	3.00	0.75	1.13	M-2	60-62Rc		
341	1	2637_F1C01	SLIDE YOKE	3.50	4.00	1.63	A-2	59-61Rc		
342	1	2637_F1C02	SLIDE	2.25	3.75	1.13	A-2	59-61Rc		
343	4	2637_F1C03	YOKE CAP	3.50	3.25	0.37	A-2	59-61Rc		
344	4	2637_F1C04	BACK PLATE	3.50	1.00	2.50	A-2	59-61Rc		
345	1	2637_F1C21	SLIDE YOKE	3.50	4.00	1.63	A-2	59-61Rc		
346	1	2637_F1C22	SLIDE	2.25	3.75	1.13	A-2	59-61Rc		

PARTS LIST FOR JOB No. 2208 - PROGRESSIVE DIE									FORM DIE ASSEMBLY	
LINE ITEM	QTY	DWG No.	DESCRIPTION	X SIZE	Y SIZE	Z SIZE	MATL	HT TR	ORDER No.	VENDOR
347	1	2637_F1C23	INSERT HOLDER	2.24	0.75	1.11	S-7	46-48Rc		
348	1	2637_F2C01	SLIDE YOKE	3.50	4.00	1.63	A-2	59-61Rc		
349	1	2637_F2C02	SLIDE	2.25	3.75	1.13	A-2	59-61Rc		
350	1	2637_FD01	FORM DIE INSERT	1.00	0.75	0.62	D-2	59-61Rc		
351	1	2637_FD02	FORM DIE INSERT	1.03	1.00	1.00	D-2	59-61Rc		
352	1	2637_FD03	FORM DIE INSERT	1.03	1.00	1.00	D-2	59-61Rc		
353	1	2637_FD04	FORM DIE INSERT	0.59	2.75	0.56	D-2	59-61Rc		
354	1	2637_FD05	FORM DIE INSERT	0.59	2.75	0.56	D-2	59-61Rc		
355	1	2637_FD06	FORM DIE INSERT	1.03	1.13	1.00	D-2	59-61Rc		
356	1	2637_FD07	FORM DIE INSERT	1.03	1.13	1.00	D-2	59-61Rc		
357	1	2637_FD08	FORM DIE INSERT	0.53	2.50	2.13	S-7	50-52Rc		
358	1	2637_FD09	FORM DIE INSERT	0.50	2.50	2.13	S-7	50-52Rc		
359	1	2637_FD10	FORM DIE INSERT	1.03	1.13	1.00	D-2	59-61Rc		
360	1	2637_FD11	FORM DIE INSERT	1.03	1.13	1.00	D-2	59-61Rc		
361	1	2637_FD12	CURL INSERT	0.95	0.75	0.63	D-2	59-61Rc		
362	1	2637_FD13	CURL INSERT	0.95	0.75	0.63	D-2	59-61Rc		
363	1	2637_FDB02	DIE BLOCK - FORMING	7.00	4.25	1.89	D-2	59-61Rc		
364	1	2637_FDB03	DIE BLOCK - FORMING	6.25	2.25	2.36	S-7	54-56Rc		
365	1	2637_FDB04	DIE BLOCK - FORMING	6.25	4.00	2.36	S-7	59-61Rc		
366	1	2637_FDB05	DIE BLOCK - FORMING	6.25	2.25	2.36	S-7	54-56Rc		
367	2	2637_G09	GUIDE RAIL	6.50	0.75	0.25	A-2	52-54Rc		
368	1	2637_G10	GUIDE RAIL	9.00	1.00	0.50	S-7	52-54Rc		
369	1	2637_G11	GUIDE RAIL	7.75	1.00	0.50	S-7	52-54Rc		

PARTS LIST FOR JOB No. 2208 - PROGRESSIVE DIE									FORM DIE ASSEMBLY	
LINE ITEM	QTY	DWG No.	DESCRIPTION	X SIZE	Y SIZE	Z SIZE	MATL	HT TR	ORDER No.	VENDOR
370	1	2637_G12	GUIDE RAIL	6.25	0.75	0.25	A-2	52-54Rc		
371	2	2637_MISC01	PILOT PIN				M-2		5/16 REAMER BLANK	
372*	2	2637_MISC02	KEY	3.00	0.50	0.50	A-2	58-60Rc		
373	3	2637_MISC03	SUPPORT GIB	2.12	0.75	0.33	A-2	59-61Rc		
374	4	2637_MISC05	LIFTER KEEPER	1.50	2.50	1.00	4140	PRE-HARD		
375	2	2637_SD01	SHEDDER	0.43	1.00	0.69	4140	PRE-HARD		
376	10	2637_SP01	RAIL LIFTER	DIA	0.87	4.50	A-2	59-61Rc		
377	4	2637_SP03	LIFTER PIN	DIA	0.75	4.50	A-2	59-61Rc		
378	1	2637_TC01	TRIM SLIDE	3.75	5.00	1.25	A-2	59-61Rc		
379	1	2637_TC02	TRIM SLIDE RETAINER	5.25	5.00	0.50	A-2	59-61Rc		
380	1	2637_TC03	BACK PLATE	5.25	2.50	2.50	A-2	59-61Rc		

PARTS LIST FOR JOB No. 2208 - PROGRESSIVE DIE									FORM PUNCH ASSEMBLY	
LINE ITEM	QTY	DWG No.	DESCRIPTION	X SIZE	Y SIZE	Z SIZE	MATL	HT TR	ORDER No.	VENDOR
401	12		DOWEL PIN - 5/16 DIA x 1-1/4				FASTENER			
402	2		SHCS - 1/4-20 x 7/8				FASTENER			
403	7		BALL LOCK RETAINER - HRT 37				PUR	PUR	HRT 37	DAYTON
404	5		SHCS - 1/2-13 x 1-1/2				FASTENER			
405	20		SHCS - 5/16-18 x 1-1/4				FASTENER			
406	5		SHCS - 5/16-18 x 1-3/4				FASTENER			
407	4		SHCS - 1/4-20 x 1-1/2				FASTENER			
408	7		PUNCH - PILOT				M-2	PUR	HPA 37-D350 P.315	DAYTON
409	2	2637_F1C05	SLIDE DRIVER	4.00	2.50	4.12	S-7	56-58Rc		
410	2	2637_F1C25	SLIDE DRIVER	4.00	2.50	3.87	S-7	56-58Rc		
411	1	2637_FP01	FORM PUNCH INSERT	6.25	1.75	1.95	D-2	59-61Rc		
412	1	2637_FP02	FORM PUNCH INSERT	1.00	1.00	0.87	D-2	59-61Rc		
413	1	2637_FPU02	PUNCH - FORMING	6.25	4.50	3.75	4140	FLM-HDN		
414	1	2637_STR03	STRIPPER	32.50	7.50	1.00	4140	PRE-HARD	ORDER AS BURNOUT - SEE DETAIL	
415	1	2637_TC06	TRIM SLIDE DRIVER	5.00	2.50	4.14	A-2	59-61Rc		

PARTS LIST FOR JOB No. 2208 - PROGRESSIVE DIE									PIERCE & CUTOFF DIE ASSEMBLY	
LINE ITEM	QTY	DWG No.	DESCRIPTION	X SIZE	Y SIZE	Z SIZE	MATL	HT TR	ORDER No.	VENDOR
501*	2		DOWEL PIN - 3/16 DIA x 3/4				FASTENER			
502	8		SHCS - 10-32 x 3/4				FASTENER			
503	2		SHCS - 1/4-20 x 1-1/2				FASTENER			
504	4		DOWEL PIN - 5/16 DIA x 1-1/4				FASTENER			
505	5		SHCS - 5/16-18 x 7/8				FASTENER			
506*	2		SHCS - 1/4-20 x 5/8				FASTENER			
507	9		SHCS - 5/16-18 x 1-1/4				FASTENER			
508	1		PROXIMITY SENSOR (12MM)				PUR		BI 2-G12K-AN6X	TURCK
509*	1		DIE SPRING				PUR		9-1622-11 (!" x 5-1/2" MED DUTY)	DANLY
510	2		DIE SPRING				PUR		DIA 1/2 x 5-1/2 MED DUTY (CUT FROM 12" SPRING)	DANLY
511	1	2637_DB12	DIE BLOCK	6.38	4.50	1.50	4140	59-61Rc		
512	1	2637_DB13	DIE BLOCK - TRIM INSERT	1.75	2.00	1.14	A-2	59-61Rc		
513	1	2637_DB14	DIE BLOCK - TRIM	3.25	2.50	0.75	A-2	59-61Rc		
514	1	2637_DB15	DIE BLOCK - CUTOFF	6.25	2.14	1.50	A-2	59-61Rc		
515	1	2637_DB16	HEEL BLOCK	6.25	2.50	1.50	A-2	59-61Rc		
516*	1	2637_MISC02	KEY	3.00	0.50	0.50	A-2	58-60Rc		
517	1	2637_MISC04	BALANCER	4.50	0.75	1.06	CRS	N/A		
518	1	2637_SEN01	SENSOR HOLDER (12MM)	DIA	1.00	4.50	A-2	59-61Rc		
519	1	2637_SEN03	WIRE GUARD	DIA	1.00	4.00	NYLON	N/A		
520	2	2637_SP03	LIFTER PIN	DIA	0.75	4.50	A-2	59-61Rc		

PARTS LIST FOR JOB No. 2208 - PROGRESSIVE DIE									PIERCE & CUTOFF PUNCH ASSEMBLY	
LINE ITEM	QTY	DWG No.	DESCRIPTION	X SIZE	Y SIZE	Z SIZE	MATL	HT TR	ORDER No.	VENDOR
601	9		SHCS - 5/16-18 x 1-1/4				FASTENER			
602	6		DOWEL PIN - 5/16 DIA x 1-1/4				FASTENER			
603	4		SHCS - 1/2-13 x 1-1/2				FASTENER			
604	1		BALL LOCK RETAINER - HRT 37				PUR	PUR	HRT 37	DAYTON
605	2		PUNCH - PIERCE				M-2	PUR	BJX 10 XBR15-71 P5.20 (METRIC)	DAYTON
606	2		BALL LOCK RETAINER				PUR	PUR	BRT 10	DAYTON
607	1		PUNCH - PILOT				M-2	PUR	HPA 37-D350 P.315	DAYTON
608	1	2637_PU07	PUNCH - CUTOFF	5.00	2.75	3.25	A-2	59-61Rc		
609	1	2637_PU08	PUNCH - TRIM	1.50	2.50	3.00	A-2	59-61Rc		
610	1	2637_PU09	PUNCH - TRIM	1.75	2.38	3.00	A-2	59-61Rc		
611	1	2637_STR04	STRIPPER	12.75	6.00	0.75	4140	PRE-HARD		



PARTS LIST FOR JOB No. 2208 - PROGRESSIVE DIE									DIE SHOE ASSEMBLY	
LINE ITEM	QTY	DWG No.	DESCRIPTION	X SIZE	Y SIZE	Z SIZE	MATL	HT TR	ORDER No.	VENDOR
701	4		SHSS - 3/4 x 4				FASTENER			
702	10		SHCS - 1/2-13 x 3-1/2				FASTENER			
703	1		JUNCTION BOX				PUR		GENERIC - AS REQ'D	CUSTOMER CHOICE
704*	6		SHCS - 5/16-18 x 2-3/4				FASTENER			
705*	4		SHCS - 1-8 x 5				FASTENER			
706*	4		SHCS - 1/2-13 x 4-1/2				FASTENER			
707	6		SHCS - 3/4-10 x 3-1/2				FASTENER			
708	4		BB SLEEVE BUSHING				PUR		337-2030	SUPERIOR
709	1	2637_DS01	DIE SHOE	79.00	30.00	3.50	PUR	N/A	SEE DETAIL LAYOUT	SUPERIOR
710	4	2637_DSTP01	SETUP BLOCK	DIA	6.00	4.44	CRS	N/A		
711	4	2637_MISC10	DIE LUG	DIA	4.50	5.00	CRS	N/A		
712	1	2637_SEN08	SENSOR GUARD	4.25	3.00	2.75	ALUM	N/A		
713	1	2637_SEN09	SENSOR GUARD	2.00	4.12	2.75	ALUM	N/A		

PARTS LIST FOR JOB No. 2208 - PROGRESSIVE DIE									PUNCH HOLDER ASSEMBLY	
LINE ITEM	QTY	DWG No.	DESCRIPTION	X SIZE	Y SIZE	Z SIZE	MATL	HT TR	ORDER No.	VENDOR
801*	10		SHCS - 1/2-13 x 5-1/2				FASTENER			
802*	8		SHCS - 1-8 x 5-1/2				FASTENER			
803*	38		SHCS - M6 x 60				FASTENER			
804*	4		SHCS - M6 x 12				FASTENER			
805	2		GUIDE POST				PUR		5-0614-5	IEM/DANLY
806	4		BALL CAGE				PUR		335-2028	SUPERIOR
807	4		BB GUIDE PIN				PUR		331-2040	SUPERIOR
808	21		GAS SPRING				PUR		LJ.300.025.TO.1750	DADCO
809	19		PAD RETAINER - 162-450R				PUR		162-450R - (IEM)	IEM
810	1	2637_DS02	PUNCH HOLDER	79.00	30.00	3.00	PUR	N/A	SEE DETAIL LAYOUT	SUPERIOR
811	4	2637_PA08	MOUNTING PARALLEL	4.50	30.00	5.56	CRS	N/A		
812	5	2637_PA09	PARALLEL	3.00	30.00	5.56	CRS	N/A		

PARTS LIST FOR JOB No. 2208 - PROGRESSIVE DIE									QUICK CHANGE PLATE ASSEMBLY	
LINE ITEM	QTY	DWG No.	DESCRIPTION	X SIZE	Y SIZE	Z SIZE	MATL	HT TR	ORDER No.	VENDOR
901	8		SHCS - 1/2-13 x 1-1/4				FASTENER			
902	4		SHSS - 3/4 x 2-1/2				FASTENER			
903*	6		SHCS - 3/4-10 x 3-1/2				FASTENER			
904*	12		SHCS - 1/2-13 x 4				FASTENER			
905	2	2637_MISC06	20" SPACER	20.00	6.00	1.75	CRS	N/A		
906	2	2637_MISC07	10" SPACER	10.00	6.00	1.75	CRS	N/A		
907	4	2637_MISC09	DIE PLATE HOOK				WLDM		SEE DETAIL	
908	1	2637_MT01	BOLSTER MOUNTING PLATE	108.00	48.00	2.00	HRS	N/A		
909	1	2637_PA01	MOUNTING PARALLEL	4.00	30.00	9.50	CRS	N/A		
910	2	2637_PA02	PARALLEL	3.00	30.00	9.50	CRS	N/A		
911	1	2637_PA03	MOUNTING PARALLEL	4.00	30.00	9.50	CRS	N/A		
912	1	2637_PA04	MOUNTING PARALLEL	4.00	30.00	9.50	CRS	N/A		
913	1	2637_PA05	PARALLEL	3.00	30.00	9.50	CRS	N/A		
914	1	2637_PA06	PARALLEL	3.00	30.00	9.50	CRS	N/A		
915	1	2637_PA07	PARALLEL	3.00	30.00	10.00	CRS	N/A		